

**DURCON
EPOXY**

**DESIGN
GUIDE**

DURCON[®]
A WILSONART COMPANY

DURCON EPOXY DESIGN GUIDE

CONTENTS

INTRODUCTION	3
I. DRAWING REQUIREMENTS	6
II. EPOXY FORMULATION	7
III. COLORS	8
IV. EDGES	9
V. SURFACES	10
VI. THICKNESS	13
VII. JOINTS	13
VIII. CUTOUTS	14
IX. CURBS (BACKSPLASHES)	15
X. SERVICE CHASES (BOX CURBS)	17
XI. ISLANDS/PENINSULAS	18
XII. SHELVING/PEGBOARDS	19
XIII. MOBILE CARTS	20
XIV. STUDENT TABLETOPS	20
XV. FUME HOOD BASES (WORKSURFACES)	20
XVI. BALANCE TABLES	21
XVII. SINKS	22
XVIII. SPECIALTY SINKS	28
XIX. CUPSINKS	28
XX. TROUGHS	29
XXI. SINK UNITS (WORKSURFACES)	30
XXII. LIGHT REFLECTANCE VALUE	31
XXIII. INSTALLATION	31
XXIV. CERTIFICATIONS	31
XXV. LABORATORY SPECIFICATIONS	32
XXVI. REFERENCE INFORMATION	40
XXVII. EPOXY RESIN CHEMISTRY	42
XXVIII. GLOSSARY	43
XXIX. CONTACT INFORMATION	49
XXX. NOTES	50

v.2023-17

DURCON EPOXY DESIGN GUIDE

INTRODUCTION

Laboratory Countertop Selection

As appeared in R&D Magazine

The laboratory worksurface is by far the single most visible and interacted with component of any laboratory. Since the late 1980s, when epoxy resin replaced cement asbestos as the industry standard for lab worksurfaces, manufacturers have strived to refine countertop designs to perform beyond the chemical, heat and load bearing requirements of the research lab. It is now possible to select between modular designs, colors and many additional safety and aesthetic options to individually tailor each laboratory's efficiency, accuracy, comfort and precision for various applications.

Designing for Precision/Reconfiguration

Typically, new laboratory worksurfaces are required for new facilities, the reconfiguration of existing space or for a complete retrofit. Workspaces designed with a degree of flexibility are recommended due to R&D labs' project specific nature (the useful life of an R&D lab is on average very short and may require alterations as often as every three to five years). Long-term savings can be achieved by forecasting future requirements and specifying appropriate countertops (and supporting cabinetry) in the initial construction of the facility.

Worksurface Evaluation Criteria

The lab owner in conjunction with the architect, the lab manager and in some cases the lab user should specify the type (or types) of worksurfaces required in the initial design phase of a lab project. Worksurface evaluations should be based upon individual lab requirements for:

- Resistance to the chemicals to be used
- Heat resistance
- Liquid absorption
- Load bearing capabilities
- Impact and abrasion resistance
- Electrical conductivity
- Liquid containment and liquid disposal (especially in sink areas and fume hoods)
- Ease of maintenance
- Ergonomics
- Availability
- ADA compliance
- Color
- Overall appearance
- Special requirements (i.e. irregular shapes, minimal joints, etc.)

DURCON EPOXY DESIGN GUIDE

Each lab design project will have unique worksurface requirements; however, depending upon laboratory classification, some general guidelines can be supposed:

- Chemistry Use Area (i.e. Organic, Inorganic, Bio-chemical, Analytical) – consideration should be given to chemical resistance, ease of cleaning, color suitability, strength, abrasion resistance and thermal shock resistance.
- Physics Use Area – consideration should be given to physical strength, abrasion resistance, impact resistance and heat resistance.
- Biology Use Area – consideration should be given to stain resistance, ease of cleaning, abrasion resistance plus bacteria and fungus resistance.
- Special Purpose Use Areas Where Chemical Resistance is a Prime Consideration (i.e. pathology/ hematology and other special biochemical areas) – consideration should be given to impermeability and ease of cleaning.

Special Purpose Use Areas where chemical resistance is not a prime consideration:

- Electronics – consideration should be given to physical strength and other task specific characteristics.
- Electrical – consideration should be given to insulation characteristics, dielectric strength and physical strength.
- Mechanical – (i.e. metallurgical, geological, etc.) – consideration should be given to resistance to physical abuse.
- Radioactive – consideration should be given to contamination by radioactive material.
- Thermal – consideration should be given to temperature requirements.

Certainly other classifications exist and practical combinations of the above laboratory types are numerous.

For safety, evaluate worksurface needs based upon the usage in the hardest impacted areas of the lab. Typically fume hoods and sink areas see the majority of harsh chemicals and reactions.

The Selection Process

Once the worksurface requirements have been specified, various materials and styles can be evaluated for compliance. The three most popular worksurfaces used today are epoxy resin, plastic laminate and phenolic resins. To facilitate the selection process, many worksurface manufacturers perform and publish the results of chemical resistance tests that evaluate worksurface resistance to the chemicals commonly used in lab environments, as well as physical properties tests which evaluate standard measurements for hardness, flammability and deflection. These tests are provided as guidelines. Carefully evaluate results between various material types and between individual material manufacturers as occasionally results are impacted due to dissimilar testing methods.

DURCON EPOXY DESIGN GUIDE

A variety of resources are available to help identify and evaluate worksurface materials and manufacturers. SEFA (Scientific Equipment and Furniture Association) is a non-profit organization dedicated to the enhancement of member company performance and the improvement of the quality and timely completion of laboratory facilities. The SEFA web site, www.sefalabs.com, provides a wealth of lab design information and links to member's web pages as well as government regulating agencies.

Innovative Worksurfaces & More

*As featured in **Construction in Focus** magazine March 2019 edition, written by Robert Hoshowsky*

Renowned for manufacturing high-quality epoxy worksurfaces, sinks and accessory systems engineered to withstand harsh chemicals and high temperatures, Durcon A Wilsonart Company® is the world's largest producer of epoxy tops for laboratories. The company's worksurfaces and sinks are famous for their durability and are found in research facilities, public schools, universities, and government and industrial sectors around the world.

“Our products outlast the buildings they are in, which would fall apart around them before the epoxy corrodes... very hard to destroy.”

The story of Durcon is one of technological innovation, ingenuity, evolution and recognizing the needs of the marketplace. Back in the early sixties, parent company Duriron began fabricating piping and fittings from epoxy resins – also known as polyepoxides – which had outstanding fire and chemical resistance. At the time, laboratories were still using thick slabs of quarried stone as worksurfaces, and epoxy resin was applied to make them better withstand day-to-day challenges from chemicals and heat. As the laboratory market grew, the decision was made in the seventies to branch off from Duriron. The name changed to Durcon, and the focus shifted to fabricating durable epoxy worksurfaces.



DURCON EPOXY DESIGN GUIDE

I. DRAWING REQUIREMENTS

- A. Complete drawing set, in PDF or .dwg format, is required. Include:
1. Title Sheet
 2. Fixture List / Information Sheet
 3. Floor Plans
 4. Elevation Details
 5. Top Details
 6. Detail Sheets
 7. Cut sheet submittal package with cutout requirements (service fixtures, sinks, grommets, etc.)

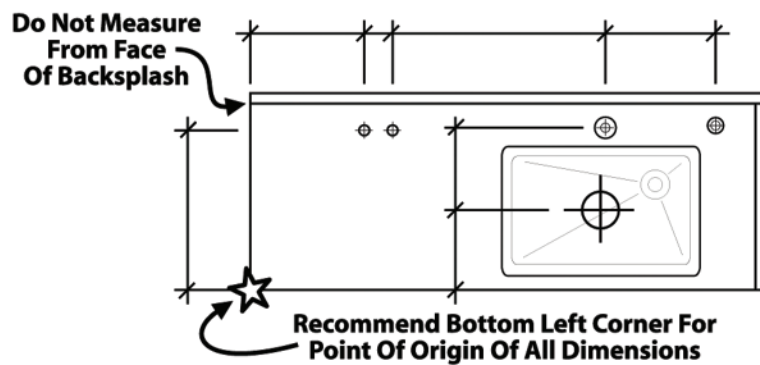

- B. Specify worksurface dimensions from the edges and not from any other surface such as the backsplash. Durcon's point of origin for all drawings is the lower left hand corner of a piece or assembly.
- C. Ensure that top lengths and cutout locations match elevations (if discrepancies are detected, worksurface drawings supersede all others).
- D. On large projects try to standardize the sizes of multiples of any type of unit (this allows us the option to mold instead of glue to reduce cost and provide a better product).
- E. Detail the drawing to clarify top material of each piece with:
1. e = epoxy
 2. eg = epoxy greenstone
 3. pl = plastic laminate
 4. ss = stainless steel

DURCON EPOXY DESIGN GUIDE

5. p = phenolic or compact laminate
 6. scr = solicor-cr
 7. sls = solid surface
- F. Specify piece size and weight limitations.
1. Singular epoxy worksurface pieces can be molded up to 96" x 72".
 2. Epoxy resin tops 1" thick weigh approximately 11 lbs. per square foot.
 3. Singular phenolic worksurface pieces are available up to 120" x 60".
 4. Phenolic tops 1" thick weigh approximately 7.4 lbs. per square foot.
- G. Special cutouts such as stainless steel sinks, grommets and vandal resistant fixtures require a cut sheet and fixture orientation to ensure correct positioning **(templates will not be accepted)**.
- H. Minimize double facing (finished on both top and bottom sides) on pegboards and shelves. We do not double face shelves that are less than 18" above the worksurface.
- I. Layered surfaces should not be drawn over tops. Separate drawings to eliminate confusion.
- J. Specify pallet size and weight limitations when necessary (2500-3000 lbs.).
- K. Indicate on each elevation if tops are being installed prior to struts or uprights.
- L. Specify if tops are to be palletized by room, floor, etc., when P.O. and drawings are submitted.
- M. Epoxy tops must be adequately supported throughout worksurface runs (cabinets, cleats, stringers, aprons, etc., can all provide support), no overhangs or cantilevers greater than 6", anything greater could result in joint failure causing the top to tilt, and will require additional support.

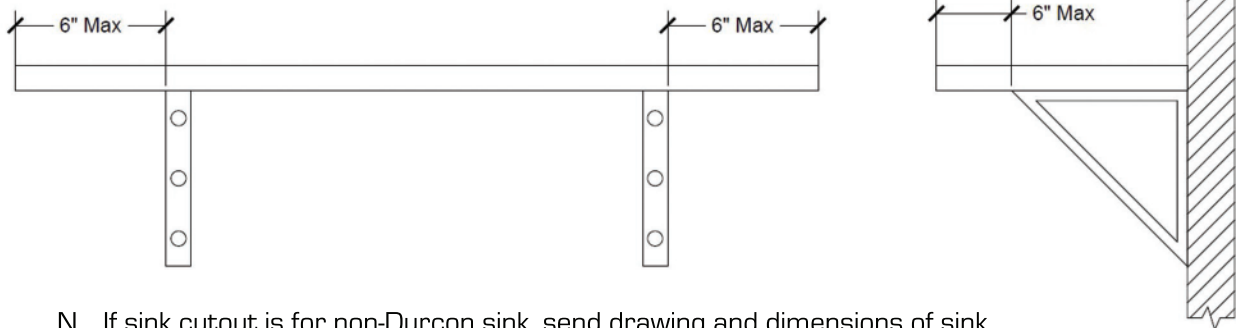

- N. If sink cutout is for non-Durcon sink, send drawing and dimensions of sink.

II. EPOXY FORMULATION

- A. Traditional – Industry standard material that provides the greatest combination of physical properties and chemical resistance, as well as heat and flame resistance.
- B. Greenstone – Based on traditional formula with at least 10% post-consumer recycled content. Complies with LEED Credits MR 5.1 & 5.2, EQ 4.1, MR 4.1 & 4.2, MR 3.1 & 3.2.

DURCON EPOXY DESIGN GUIDE

III. COLORS

- A. Specify colors clearly, by name, to ensure the correct color is provided for the project.
- B. Contact Durcon representative for current color availability and pricing.
- C. Custom Colors are available. A color chip must be submitted to Durcon when requesting a custom color. Allow a minimum of six weeks for shipment after customer approval.

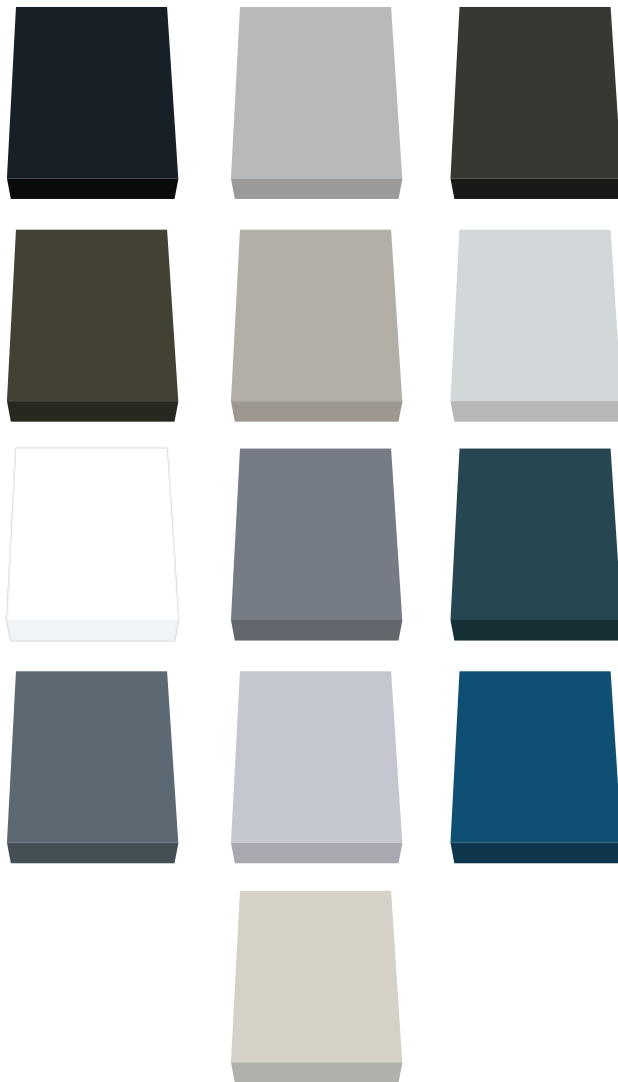

Black Onyx

Dark Khaki

Alpine White

Platinum

Gray

Tan

Slate Gray

Pearl

Sand

Graphite

Lunar White

Forest Green

Pacific Blue

DURCON EPOXY DESIGN GUIDE

IV. EDGES

A. Available edges:

ClassicTop With 1/4" Machined Radius

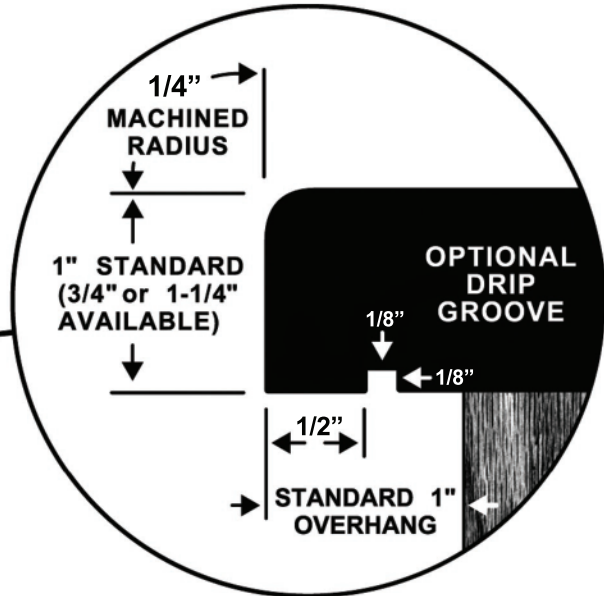
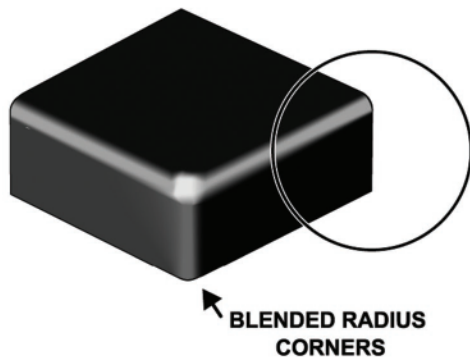

ClassicTop With 1/8" Machined Bevel

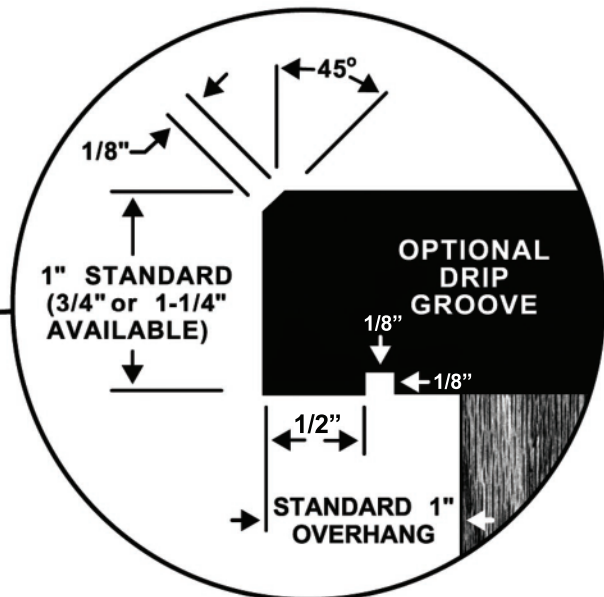
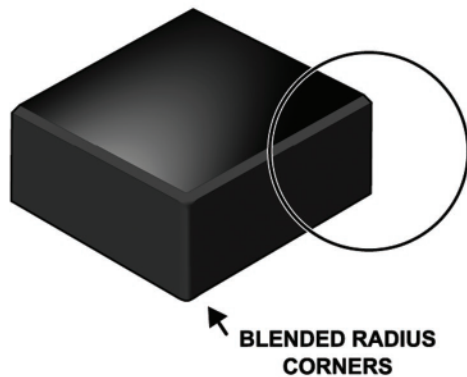

B. Supply edge finishing requirements* for each piece including:

1. RAD = 1/4" Machined Radius
2. BEV = 1/8" Machined Bevel
3. U = Unfinished

*If not specified

DURCON EPOXY DESIGN GUIDE

- C. Specify non-standard ClassicTop corner details.
 - 1. A blended radius corner is standard unless otherwise specified.
 - 2. Larger radius can be specified. An up-charge will apply.
- D. Specify edges to receive drip grooves (note: drip grooves are not standard on Fume Hood Bases and Marine Edge Tops).
- E. Standard overhang for Classic worksurfaces is 1" from face of cabinet body.

V. SURFACES

ClassicTop Marine With 1/4" Machined Radius

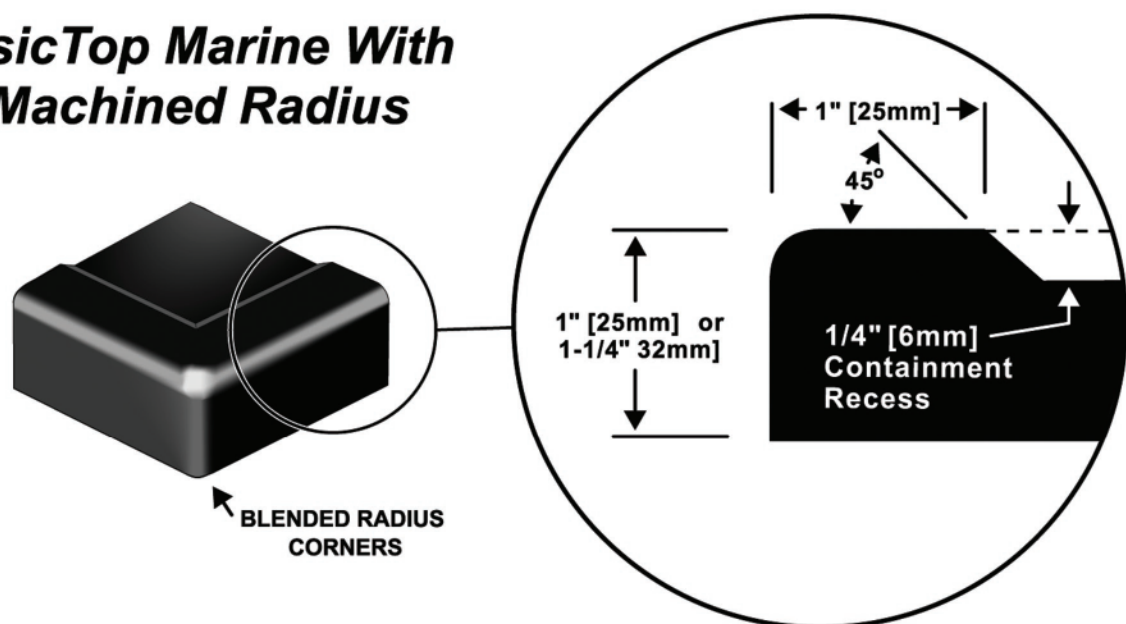

ClassicTop Marine With 1/8" Machined Bevel

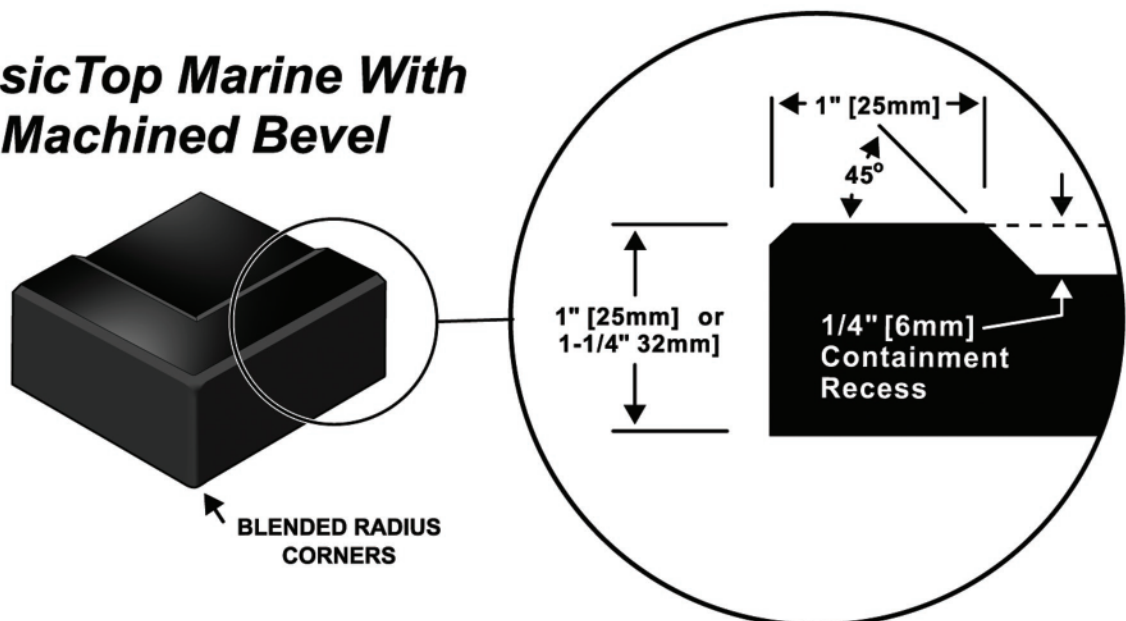

DURCON EPOXY DESIGN GUIDE

A. Select between:

1. Flat - Maximum worksurface space with the greatest configurational flexibility.
2. ClassicTop - 1/8" machined bevel or 1/4" machined radius edge.
3. Marine - Worksurface with a 1/4" raised liquid containment rim (eliminating the need for drip grooves).
4. ClassicTop Marine - Dished worksurfaces with a 1/8" machined bevel or a 1/4" machined radius are available.

B. Integrally molded ClassicTop Marine edges will be used unless configuration precludes the use of standard molds (please contact Durcon for recommended marine worksurface sizes as a substantial savings can be obtained by utilizing existing molds [or if it is a specification requirement]).

1. Where molding is not an option, the method of marine edge application is determined by Durcon to ensure maximum slab utilization (see below).

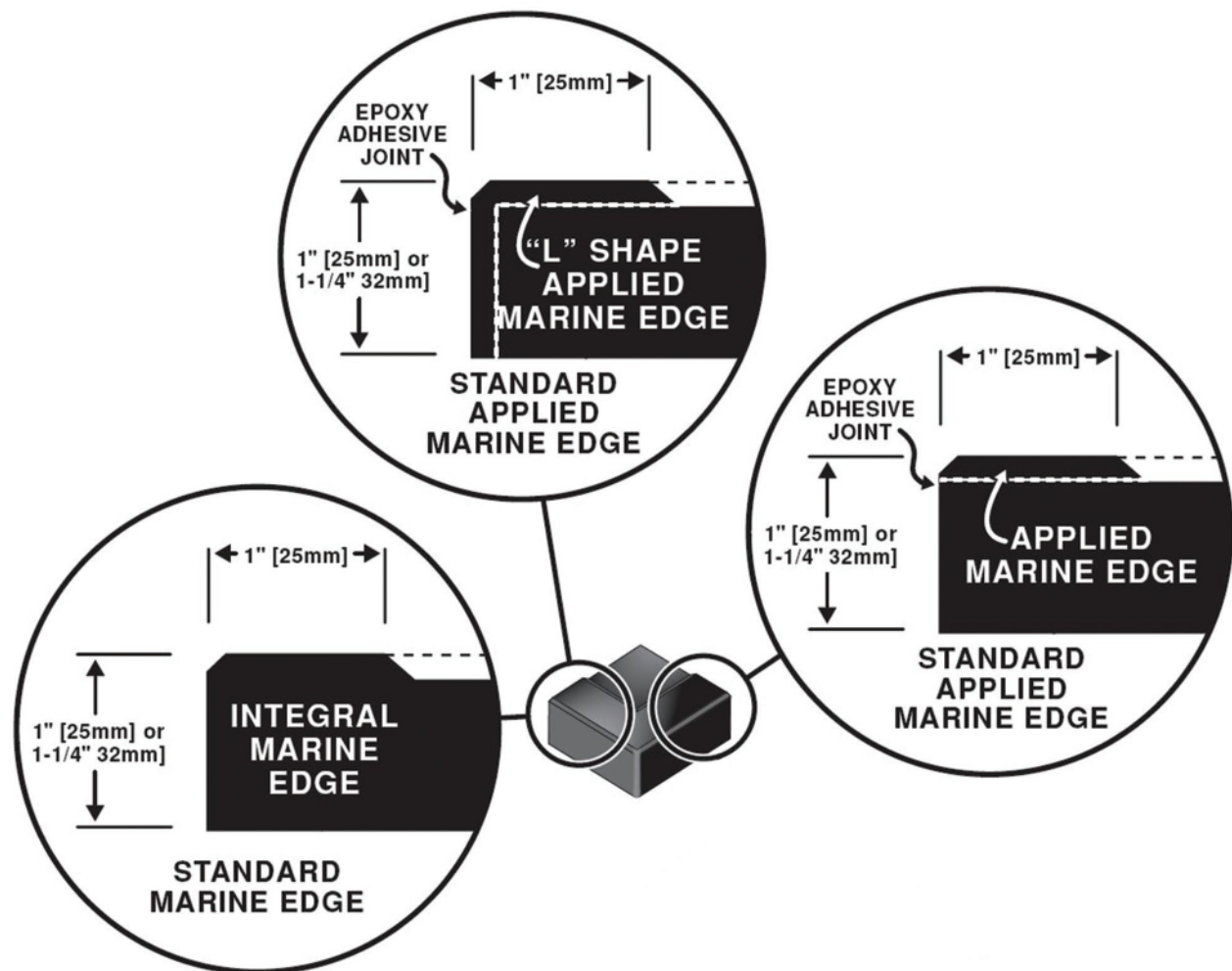

DURCON EPOXY DESIGN GUIDE

2. Standardization of sizes of marine edge tops allows for the option of molding instead of gluing, resulting in reduced costs and a better product.
- C. Applied ClassicTop Marine edges are 1/4" thick Durcon Epoxy containment strips glued to the top edge with an epoxy adhesive.
 - D. ClassicTop Marine Edges may also be applied 1/4" thick "L" shaped strips.
 - E. Use curb for containment on back edge of ClassicTop Marine worksurfaces. Stacking loose curbs on top of marine edges is acceptable but will add to the cost.

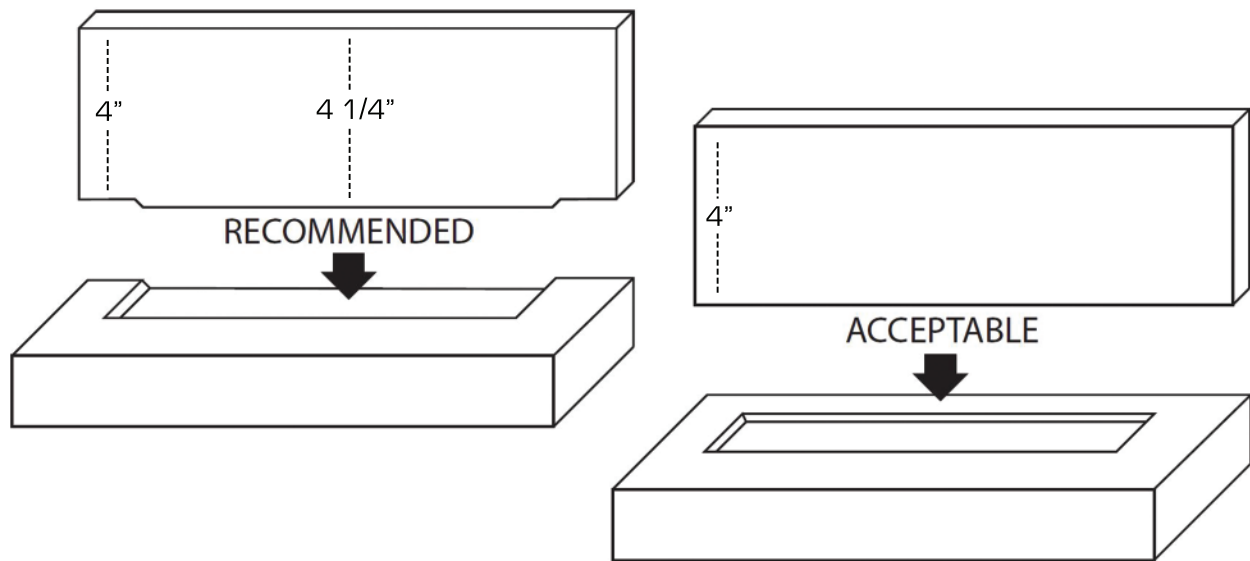

- F. Specify worksurface dimensions from the bottom left hand corner of the countertop, not from any other surface [example: do not measure from backsplash].

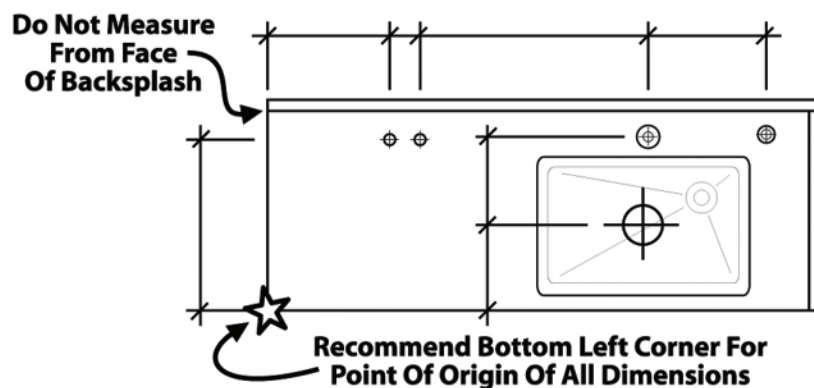

DURCON EPOXY DESIGN GUIDE

- G. Avoid seams in knee spaces and wet areas.

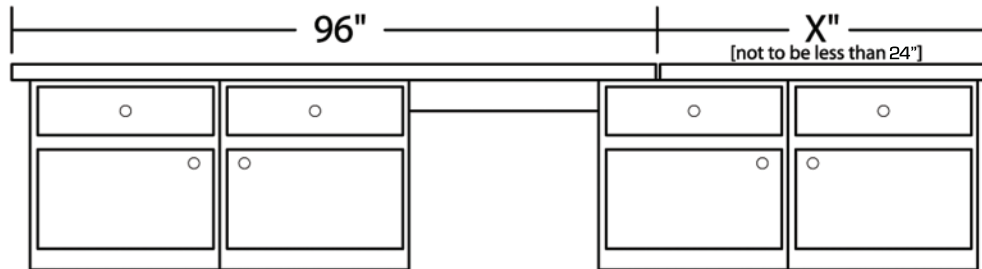

VI. THICKNESS

- A. Specify top thickness.
1. 1" thick solid epoxy resin is the industry standard. 3/4" and 1-1/4" thick worksurfaces are available for special applications.
 2. Specify marine worksurface thickness from the raised outer edge. The industry standard for marine tops is 1" thick. 1-1/4" thick outer edges are also available.
 3. Specify fume hood worksurface thickness from the raised outer edge. Durcon fume hood bases are available in the industry standard 1-1/4" thickness. 1" thick outer edges are also available for special applications (see Section XV).
 4. Standard is to use curbs of same thickness as tops for uniformity.

VII. JOINTS

- A. Durcon does not allow for joints unless joint allowance is specified by customer; our standard is 0.06".
1. Use longest stock lengths possible to minimize joints.
 2. Do not space notches, holes, or cutouts at joint.
 3. Maintain a minimum 2" of material between joints and all cutouts.
 4. Do not place joints over knee spaces or pull boards.
 5. Do not finish a run with a piece smaller than 24".

DURCON EPOXY DESIGN GUIDE

VIII. CUTOUTS

- A. Specify cutout locations from the bottom left hand corner of the worksurface section to the centerlines of the cutout.

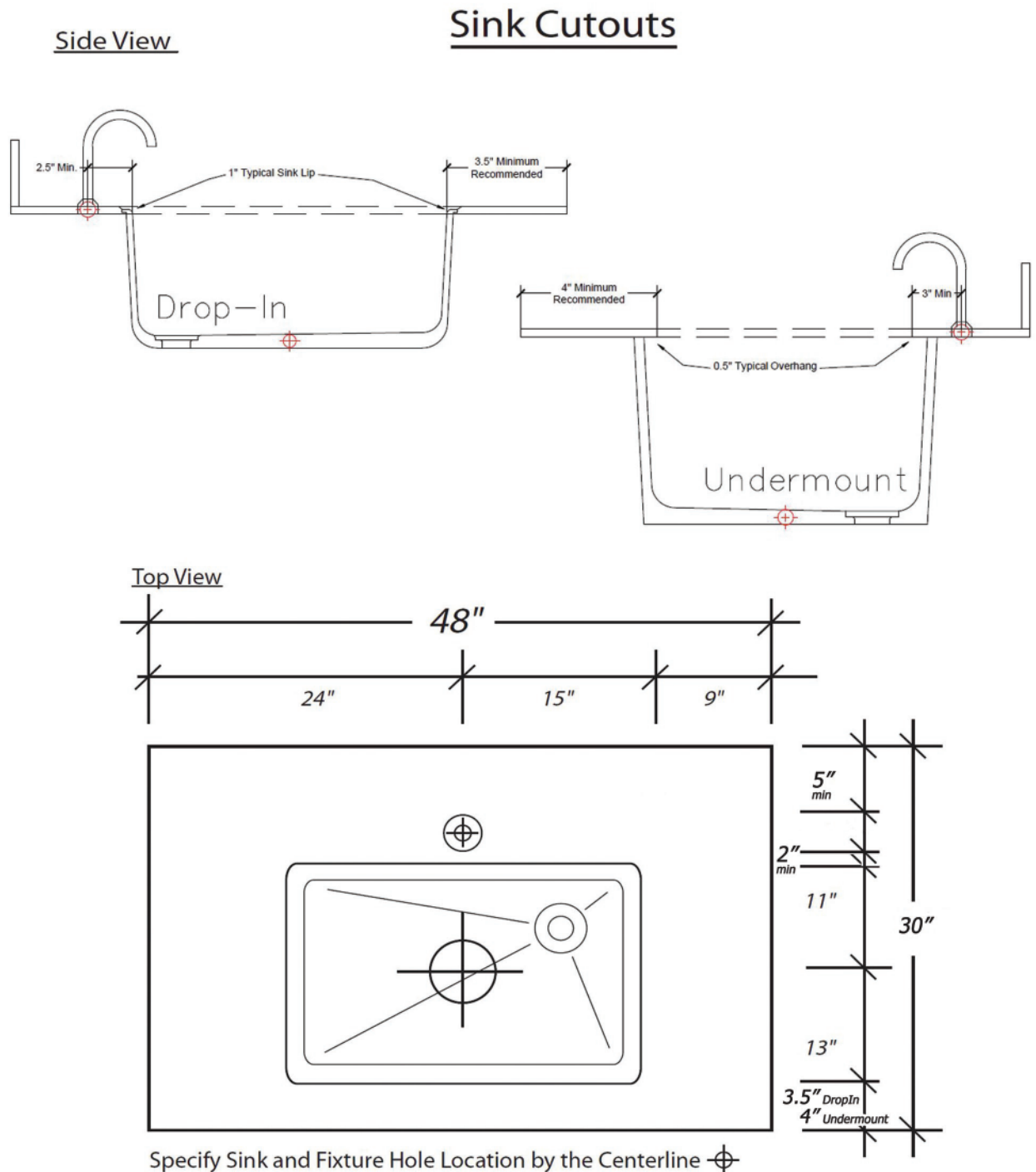

DURCON EPOXY DESIGN GUIDE

- B. The recommended location for a Dropln Sink cutout is no less than 3-1/2" from the front edge to the I.D. of the Dropln sink lip (subject to casework constraints).
- C. The recommended location for an Undermount Sink cutout is no less than 4" from the front edge to the start of the undermount sink cutout (subject to casework constraints).
- D. Tooled inner corners are standard. Specify if a squared inner corner is required (an extra charge will be applied for hand sanding square inner corners). In certain applications, enlarging the cutout for clearance will eliminate the need to square the corners.

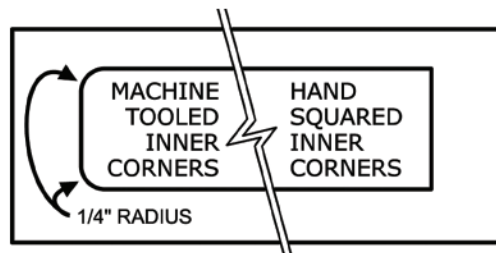

- E. Centerline required on all cutouts (example: Dropln cutouts can cause confusion when measured from edge to edge).
- F. Special cutouts for items such as stainless steel sinks, grommets and vandal resistant fixtures require a cut sheet.

IX. CURBS (BACKSPLASHES)

A. Loose curbs

1. The standard height of loose curbs is 4".
2. Loose curbs can be fabricated to any height.
3. We recommend a curb thickness equal to the worksurface thickness for 1" and 3/4" thick tops. To maximize workspace, 1-1/4" thick epoxy countertop installations should utilize 1" thick curb material.
4. Curb length is determined by worksurface length unless otherwise specified.
5. Curb length will be shortened at finished edges:
 - a. 1/8" for machined bevel edges.
 - b. 1/4" for machined radius edges.
6. The top edge of ClassicTop loose curbs can be supplied with a 1/8" machined bevel or a 1/4" machined radius.
7. Please specify preference on drawings.

We recommend using curb for containment on back edge of marine worksurfaces (See illustration in Section IV).

DURCON EPOXY DESIGN GUIDE

- B. Loose curb transitions are engineered as butt joints (not mitered).
1. If mitered joints are required, they must be fabricated on site to allow for field conditions. If specified, Durcon will supply backsplashes in sufficient lengths to allow miter cuts to be made on site.
- C. 1/4" machined radius require additional epoxy filler at intersecting corners. The filler must be carefully applied to create smooth transitions.

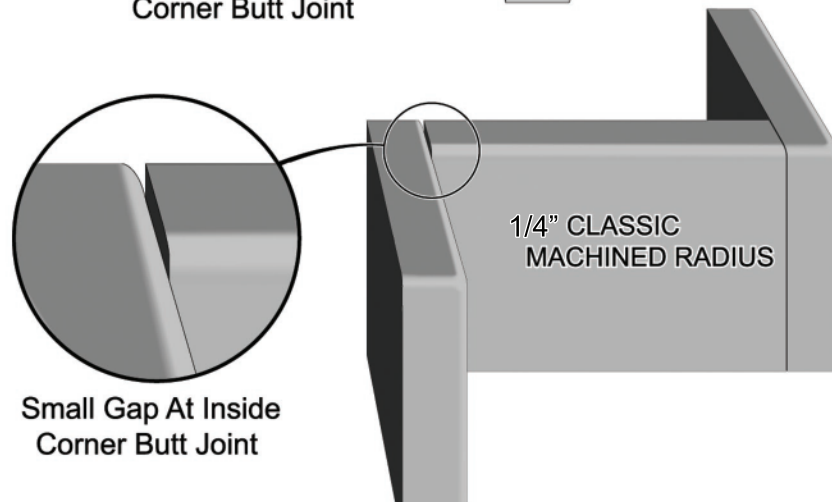
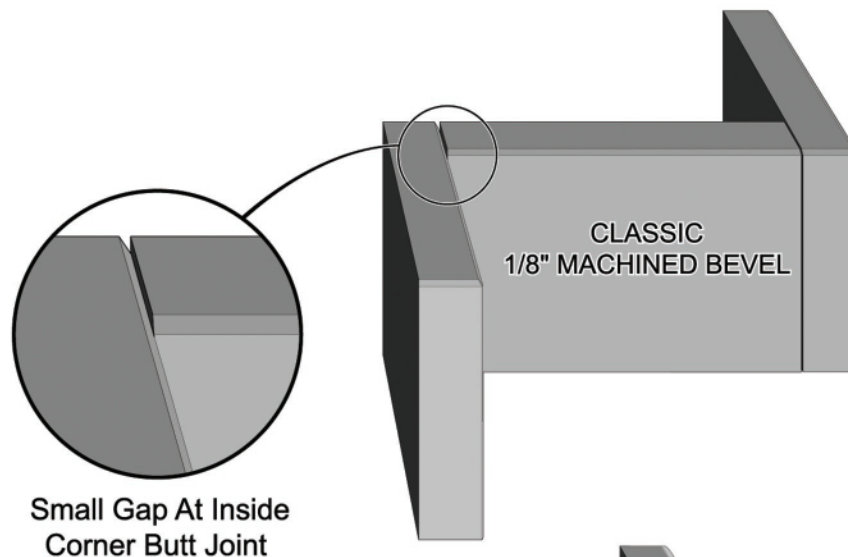

X. SERVICE CHASES (BOX CURBS)

- A. Epoxy service chases require the curb to be mounted away from the wall to allow space for piping and fixture mounts.

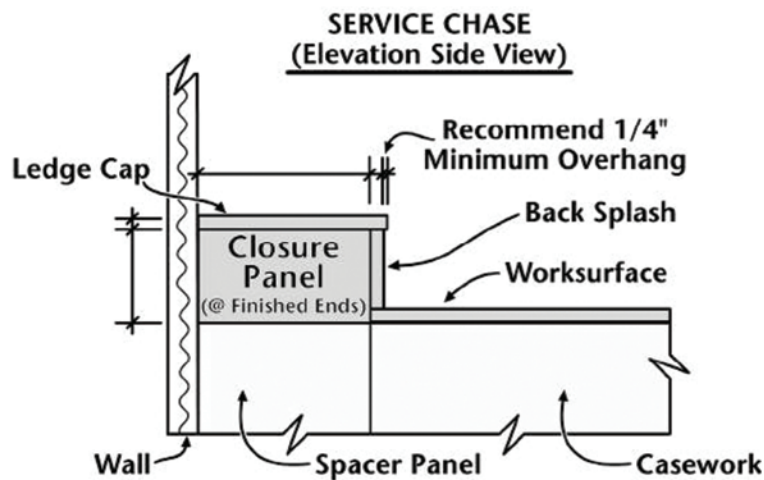

- B. The standard practice is to install the cabinet away from the wall and mount backsplash as normal. Span the horizontal space from the wall to the top of the backsplash with an epoxy resin ledge cap.
1. Allow ledge cap to overhang face of curb 1/4" (minimum).
 2. An epoxy resin closure panel can be created for exposed open ends (closure panels fit inside the service chase and are measured from the bottom of the service cap to the top of the cabinet/access panel and from the wall to the back of the curb). Please draw and specify material of all closure panels. Durcon will not supply panels unless specified.
 3. Allow enough space between sinks and front of ledge caps for fixtures (note: Durcon recommends 2-1/2" from back I.D. wall of sink to centerline of fixture hole).

DURCON EPOXY DESIGN GUIDE

XI. ISLANDS / PENINSULAS

A. Without Service Strip

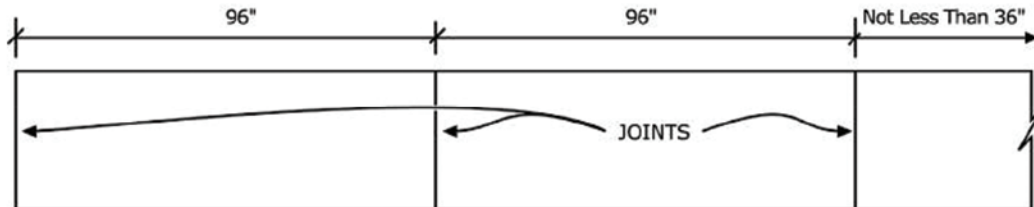

1. Worksurface joints on islands and peninsulas should be made from worksurface joints on islands and peninsulas should be made from the front edge to the back edge. Lengthwise joints should be avoided if possible.

B. With Struts or Service Strip

1. Location of joints should be determined by the sequence (location) of the struts or service strip.
2. Indicate if tops are being installed prior to unistrut or upright assembly as an installation joint is required if tops are to be installed after unistruts and other uprights are installed.
3. Minimum top length of 36" (if possible).
4. If tops must be cut under 36" wide due to pre-installed uprights or other conditions, lengthwise joints should be considered.
5. Place joints beside unistrut and upright cutouts. Avoid placing joints through the cutouts (this raises costs due to additional machining requirements).
6. Customer is to draw the joints when unistrut or uprights are present.
7. Double direction joints are to be pre-approved by customer's project manager.

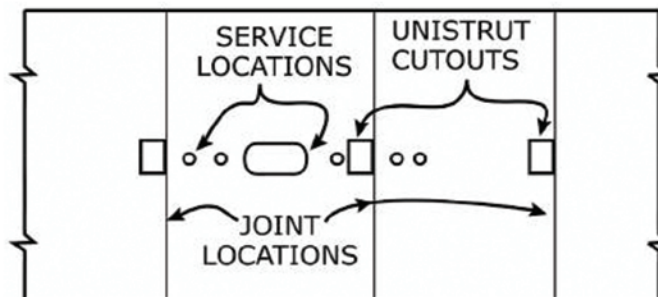

Example of Joint Location: Tops installed before unistruts assembled

DURCON EPOXY DESIGN GUIDE

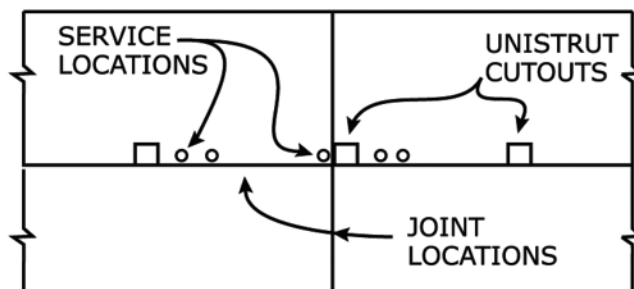

Example of Joint Location: Tops installed after unistruts assembled

C. Double Unistrut

1. Specify a separate worksurface section (core top) for the space between the unistruts (lengthwise).
2. Abut worksurfaces to each side (with unistrut cutouts).

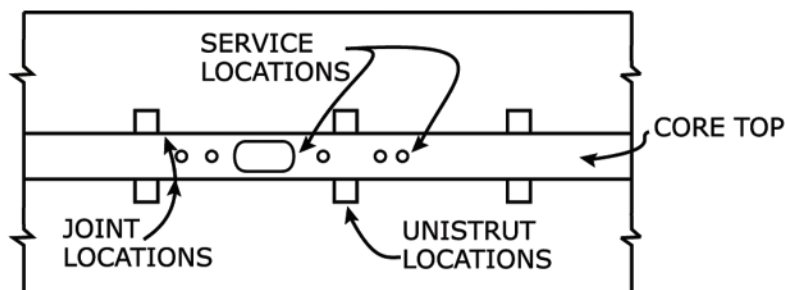

XII. SHELVING / PEGBOARDS

- A. Reagent shelves should not be drawn over tops. Separate drawings required to eliminate confusion.
- B. Machined double-faced shelves and pegboards can be supplied upon request.
- C. Specify all double-faced surfaces as "D/F" (note: we do not double-face Greenstone Epoxy).
- D. We do not double-face shelves that are less than 18" above worksurface unless specified otherwise.
- E. An up-charge will apply to all double-faced surfaces.
- F. Bottom side of double-faced surfaces will differ aesthetically from top side. Only exception will be if the top surface is not molded and machined per section B.

XIII. MOBILE CARTS

- A. Mobile cart tops should have the same dimensions as the mobile cart, with the addition of a 1/4" overhang on the front side only, to cut down on possible damage caused by mobility.

XIV. STUDENT TABLETOPS

- A. Standard sizes for student tabletops are:
1. 60" x 30"
 2. 60" x 24"
 3. 54" x 24"
 4. 48" x 30"
- B. Casters are not recommended for student tabletops with 90° corners.
- C. If casters are used, we recommend tops with radiused corners.

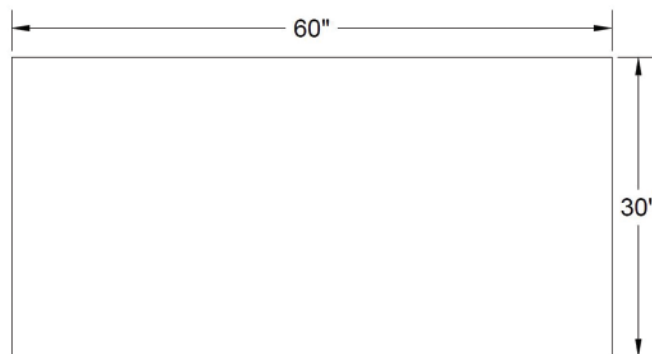

XV. FUME HOOD BASES (WORKSURFACES)

- A. Select between:
1. Classic fume hood bases are seamlessly molded in a variety of sizes and containment options to fit most fume hood cabinets.
 2. Classic fume hood bases typically have a 3/8" raised liquid containment rim.
 3. If non-standard size bases are required, custom fume hood worksurfaces may be created by the applied marine edge methods referred to in Section IV.

DURCON EPOXY DESIGN GUIDE

4. Durcon supplies either a 1/8" machined bevel or a 1/4" machined radius along the front edge. Sides are squared and finished, unless otherwise specified on customer drawings.

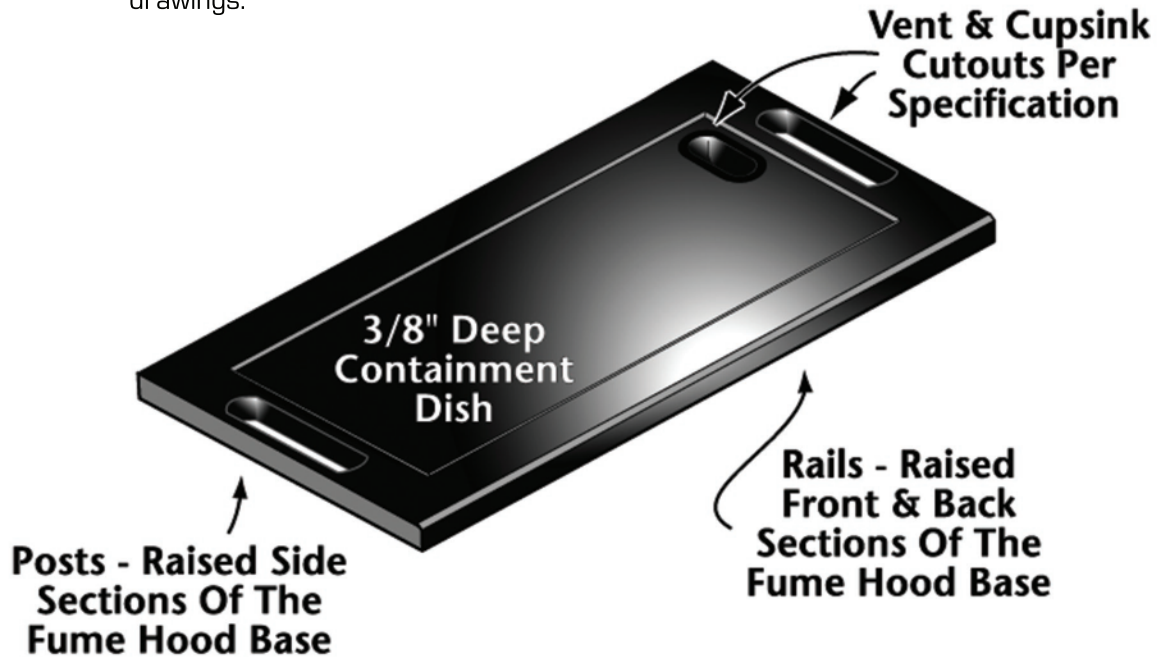

XVI. BALANCE TABLES

- A. Balance Table tops and legs consist of 2-1/2" thick, molded epoxy worksurfaces.
- B. Worksurface dimensions are 35" x 24" and stand 30" in height. Custom sizes are available.
- C. Rubberized vibration reduction pads are included to increase accuracy.

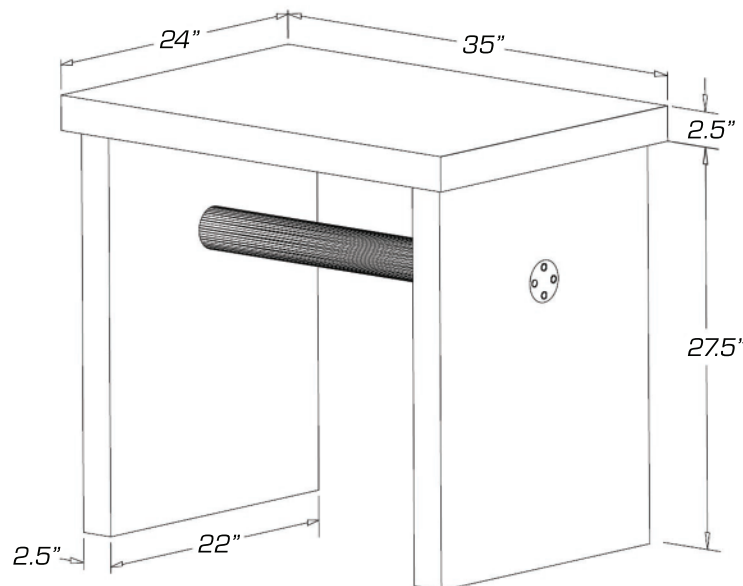

DURCON EPOXY DESIGN GUIDE

XVII. SINKS

- A. Dropln Sinks - Standard installation requires a beveled rabbet cut through the worksurface so that the lip of the rabbet cut supports the protruding sink rim. The sink rim is inset into the top below the bevel. No supports are required under the sinks. Flush or top mount installation can be specified for special applications. For a full list of available Dropln sink models and dimensions, see Durcon Epoxy Product Catalog, Page 10.

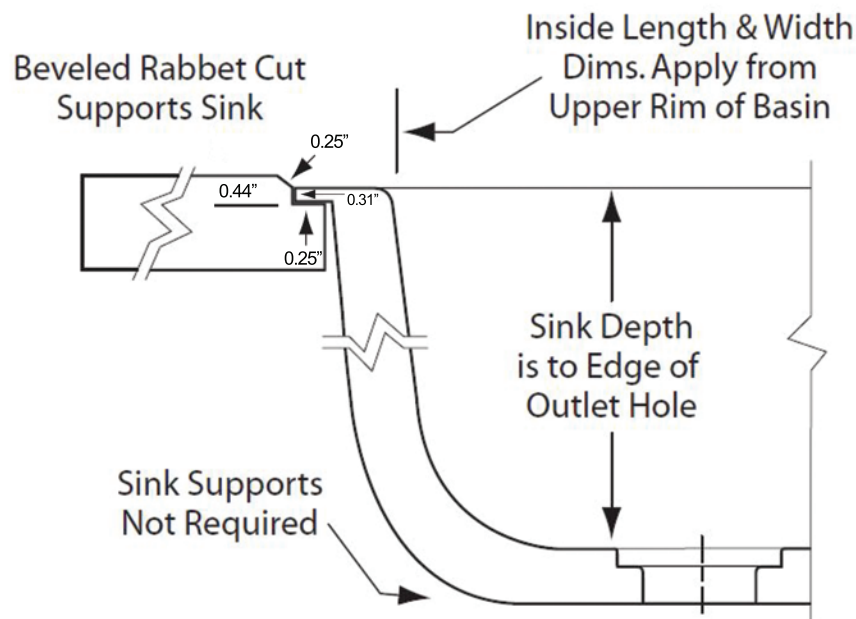

1. Supply Durcon with the Dropln sink model number or inside sink dimensions.
2. Supply the sink's centerline measured from the worksurface's bottom left corner.
3. For sink sizes and drain location, please refer to our Epoxy Product Catalog, Page 10.
4. Dropln sinks with corner drain outlets are recommended whenever practical.
 - a. Corner outlets increase storage area under the sink by locating plumbing to the rear and side of the sink cabinet.
 - b. Corner outlets help prevent draining difficulties resulting from items in the sink covering or blocking the outlet.
 - c. Corner outlets allow for a larger usable sink area when an overflow is to be used.
5. For sink covers, see Section XVII, Page 27.

DURCON EPOXY DESIGN GUIDE

B. Americans with Disabilities Act (ADA) compliant Dropln sinks are shallow basin Dropln sinks with corner drains. This design maximizes the space underneath the sink to help meet ADA requirements.

1. ADA compliant Durcon Dropln sink models and dimensions are listed in the chart below:

MODEL	OUTLET	WEIGHT	LENGTH	WIDTH	DEPTH	X-OUTLET	Y-OUTLET
A05	Corner	18 lbs	14"	10"	5"	3.5"	3.5"
A07	Corner	24 lbs	14"	14"	5"	3.5"	3.5"
A25	Corner	35 lbs	18"	15"	5"	3.5"	3.5"
A25M	Corner	30 lbs	18"	15"	2.375"	3.5"	3.5"
A26	Corner	39 lbs	18"	15"	5"/11"	4.5"	4.5"
A55	Corner	51 lbs	25"	15"	4.75"	3.5"	3.5"
A56	Corner	72 lbs	25"	15"	5"/11"	4.5"	4.5"

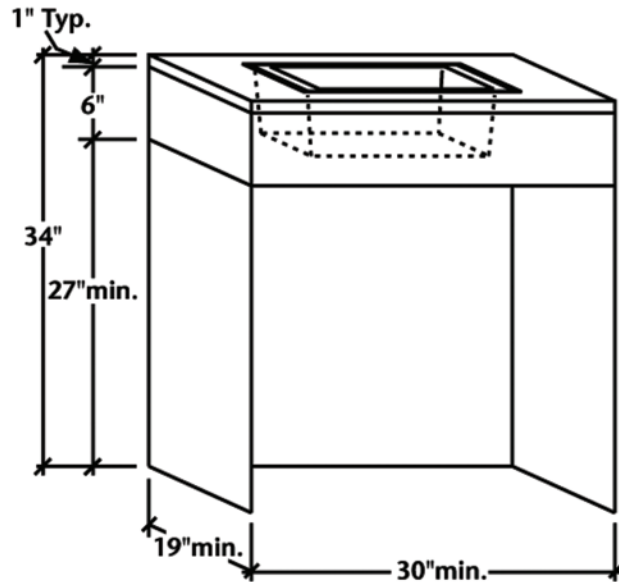

DURCON EPOXY DESIGN GUIDE

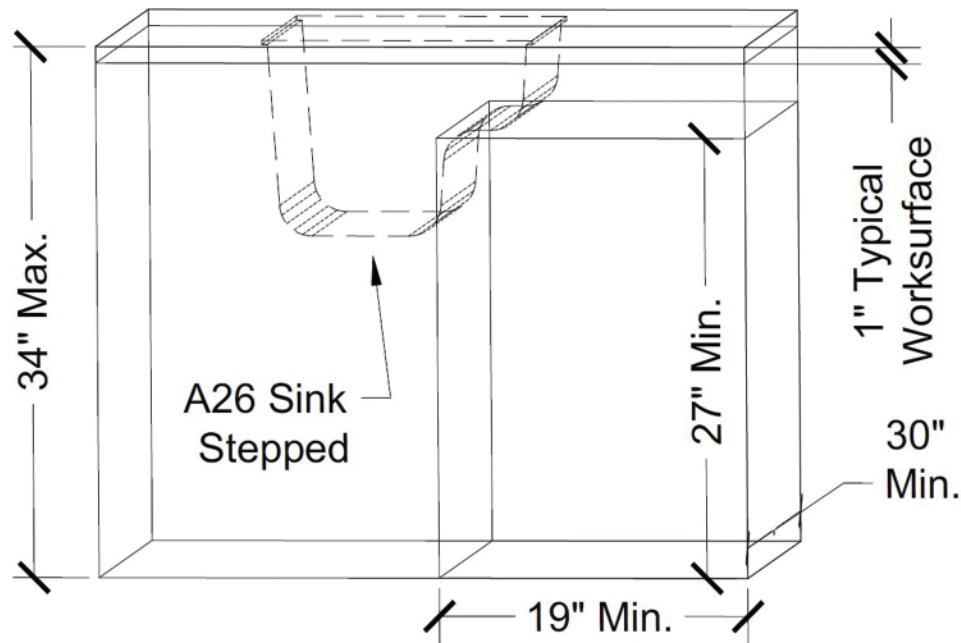

- C. The U.S. Department of Justice's Americans with Disabilities Act homepage [https://www.ada.gov/2010ADASTandards_index.htm] lists sink area compliance as:
1. 4.24.2 Height. Sinks shall be mounted with the counter or rim no higher than 34" (865mm) above the finish floor.
 2. 4.24.3 Knee Clearance. Knee clearance that is at least 27" (685mm) high, 30" (760mm) wide, and 19" (485mm) deep shall be provided underneath sinks.
 3. 4.24.4 Depth. Each sink shall be a maximum of 5-1/2" (140mm) deep.
 4. 4.24.5 Clear Floor Space. A clear floor space at least 30" x 48" (760mm x 1220mm) complying with 4.2.4 shall be provided in front of a sink to allow forward approach. The clear floor space shall be on an accessible route and shall extend a maximum of 19" (485mm) underneath the sink.

Please note: State and Local ADA Requirements override federal statutes.

DURCON EPOXY DESIGN GUIDE

- D. Undermount - Standard installation requires an eased edge cutout in the worksurface 1" smaller than the inside (length and width) dimensions of the sink unit. A 1/2" worksurface lip overhanging the sink on all sides is standard. Undermount sinks require sink supports. For a full list of available Undermount sinks and dimensions, see Durcon Epoxy Product Catalog, Page 12. **Durcon does not supply undermount sink supports.**

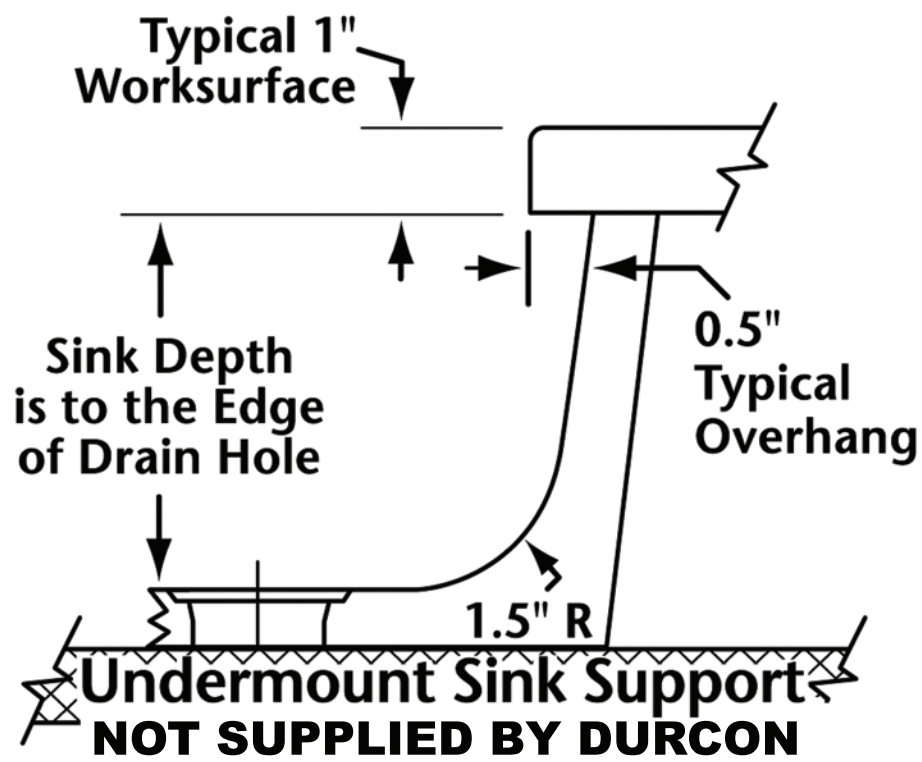

DURCON EPOXY DESIGN GUIDE

1. Supply the sink model number or inside sink dimensions.
 2. Supply the sink's centerline measured from the worksurface's bottom left corner.
 3. For sink sizes and drain location refer to the Durcon Epoxy Product Catalog, Page 12.
 4. Undermount sinks with corner drain outlets are recommended whenever practical.
 - a. Corner outlets help prevent draining difficulties resulting from items in the sink covering or blocking the outlet.
 - b. Corner outlets allow for a larger usable sink area when an overflow is to be used.
 5. Custom undermount sink depths can be created by trimming to required depths (upcharges apply).
- E. Double undermount sink installation - Two sink cutouts may be used (eliminating the expense of gluing sinks together).
1. Individual undermount sink cutouts require a minimum 2" worksurface space between the sinks.
 2. Individual sinks eliminate the need to replace both sinks if one side requires it.
 3. A single cutout for double undermount sink installation requires gluing or clamping the sinks together (upcharges apply), meaning heavier weight and shipping complications.
 4. Specify if long or short sides of sink walls are to be glued together.
 5. Specify drain location for each sink in double sink assembly (only necessary for corner and end drain sinks).

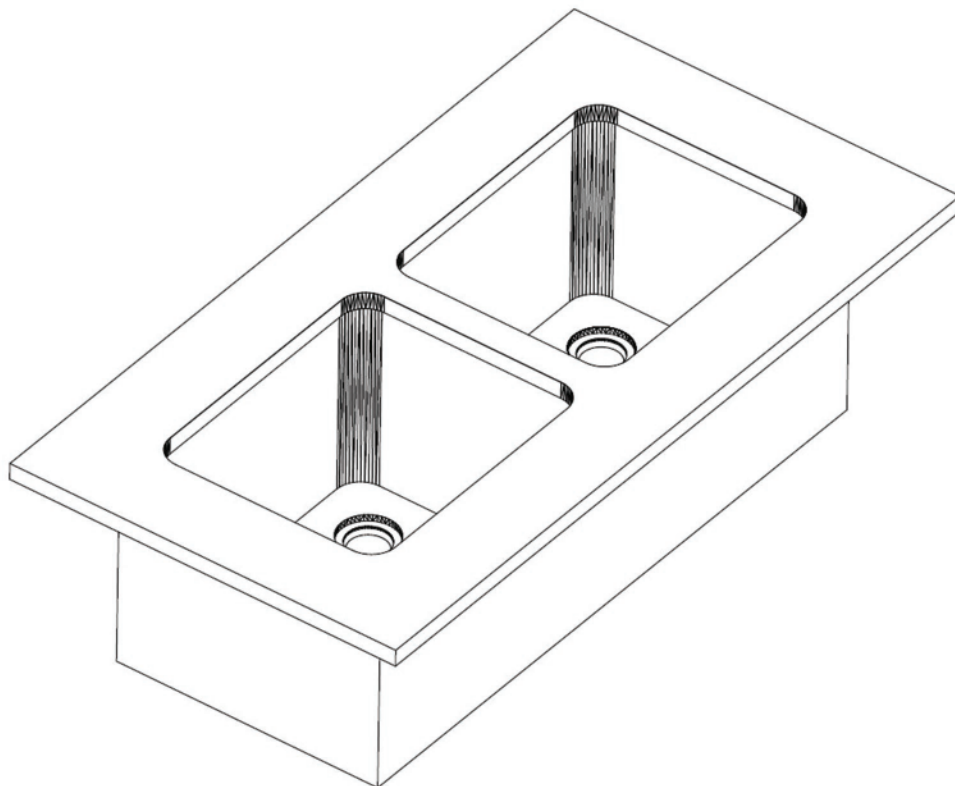

DURCON EPOXY DESIGN GUIDE

F. Sink Covers

1. Sink covers are unique for Durcon Dropln, Undermount and Cupsink sinks.
 - a. Durcon Dropln sinks require covers intended for Dropln sinks.
 - b. Durcon Undermount sinks require covers intended for Undermount sinks.
 - c. Durcon Cupsinks require covers intended for Cupsinks.
2. Recommend using Durcon SPC or Solicon-CR material for Durcon Dropln, Undermount and Cupsink covers.

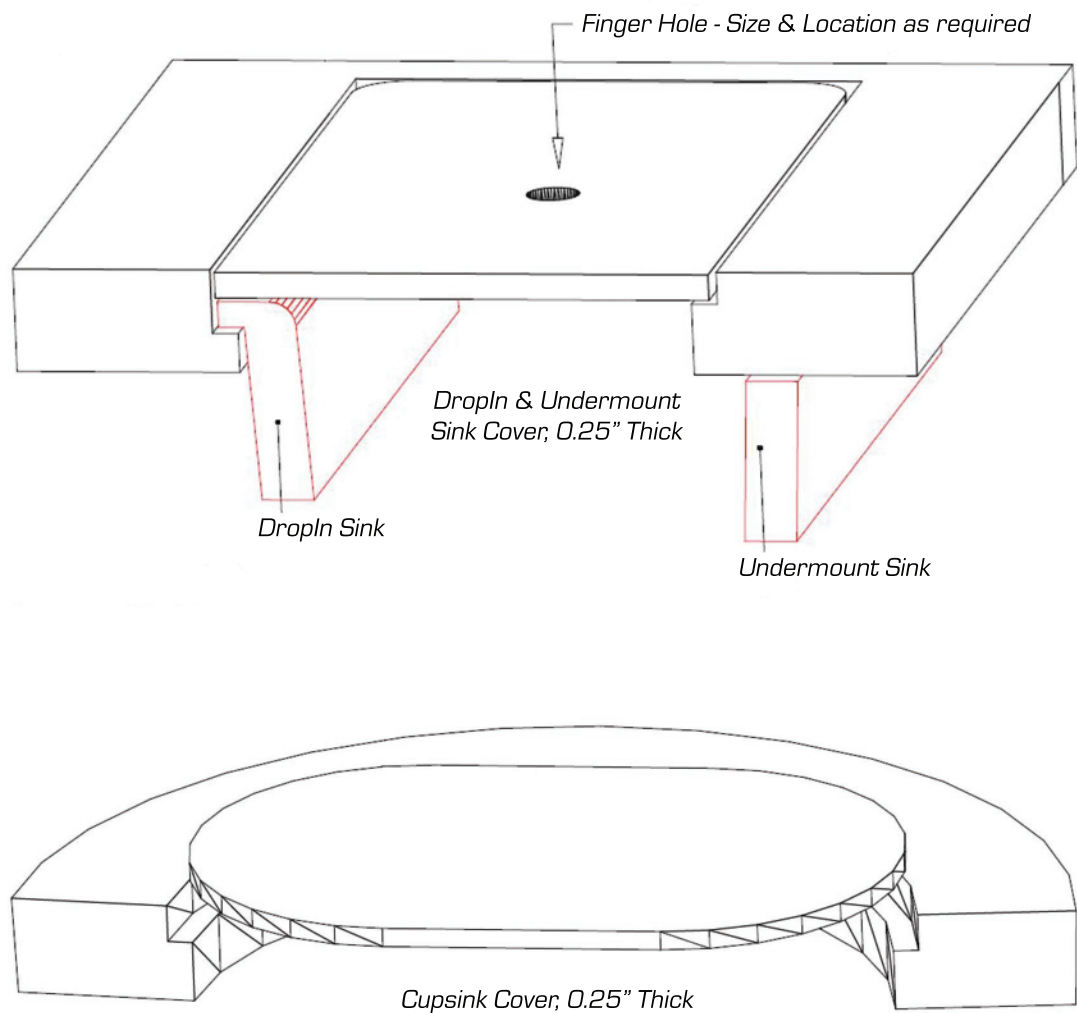

DURCON EPOXY DESIGN GUIDE

XVIII. SPECIALTY SINKS

- A. Trifacia Dropln sinks are designed for placement in Durcon Trifacia (hexagonal) workstations.
- B. Round & Elliptical sinks are available in Dropln and Undermount styles and are complementary solutions for circular or octagonal worksurface shapes.
- C. End & Wall Mount sinks are designed for placement at the end of wall runs, peninsulas and islands. For full list of End & Wall Mount models and dimensions, see Durcon Epoxy Product Catalog, Page 14.

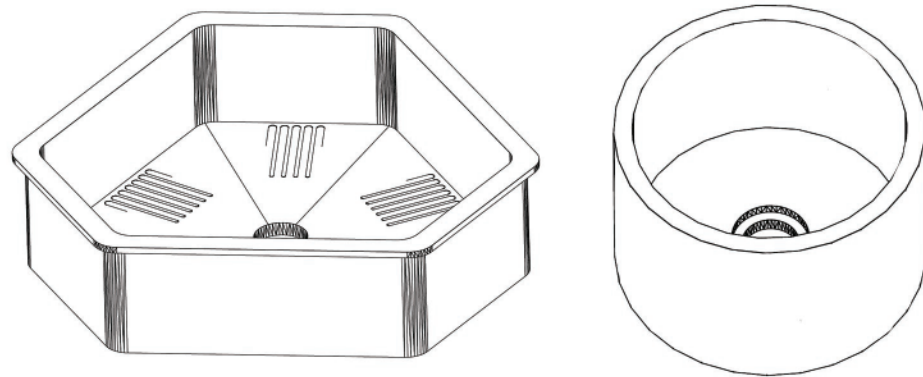

XIX. CUPSINKS

- A. Cupsinks are designed for convenient disposal of liquid waste in fume hoods or on the bench top. Durcon offers a variety of cupsink styles and shapes. Flush mounted cupsinks are standard. Please specify if an alternative installation method is required. For full list of Cupsink models and dimensions, see Durcon Epoxy Product Catalog, Page 16.

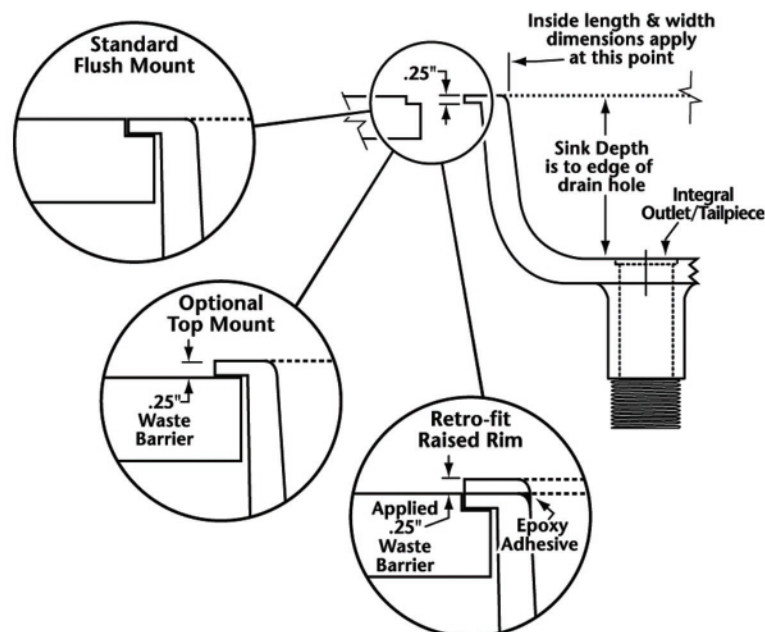

DURCON EPOXY DESIGN GUIDE

1. Flush-mounted cupsinks are standard. This installation requires a rabbet cut in the worksurface. The cupsink is installed so that the upper rim is flush with the worksurface.
2. Top mount installation can be specified to provide a 1/4" waste barrier around the cupsink basin (required in certain regions). Top mount installation requires a simple through cut in the worksurface.
3. Top mount retrofits require gluing a 1/4" tall cupsink rim over an installed flush mounted cupsink's rim.

XX. TROUGHS

- A. Sectional Troughs provide convenient disposal of liquids for multiple users. These long shallow undermount basins can be trimmed to size or joined together to create longer runs. Maximum length of sectional troughs is 18' (with end drain). For full list of available Trough models and dimensions, see Durcon Epoxy Product Catalog, Page 16.
1. Sectional trough end caps are applied before shipment.
 2. Outlet openings are machined by Durcon.
 3. Sectional troughs require a sink support for each section. **Durcon does not supply sink supports.**
 4. Trough installation kits for joining sections are available at an additional cost.
- B. DropIn Troughs are one-piece units that are installed from the top and supported by the surrounding worksurface.
- C. One piece undermount troughs with molded end caps and a molded outlet opening are available.
- D. One piece undermount troughs require sink supports. **Durcon does not supply sink supports.**

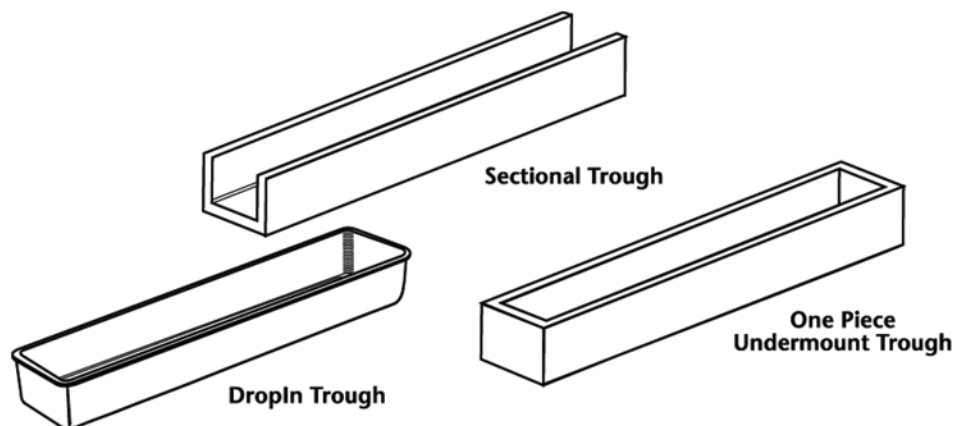

DURCON EPOXY DESIGN GUIDE

XXI. SINK UNITS (WORKSURFACES)

A. Classic MarineTop

1. The back splash provides moisture containment on the backside of the unit (recommend not stacking backsplash on marine edges [see illustration in Section IV]).
2. Recommend drain grooves be no less than 2" apart O.C.
3. Recommend 12" maximum length for DropIn sink drain grooves to maintain 1/8" per foot incline.

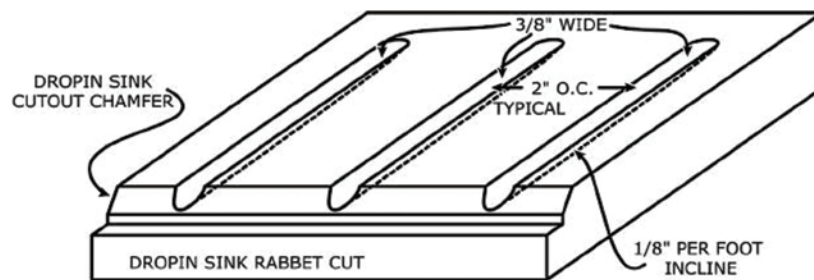

B. DrainTops - Flat sink unit with raised rib drain board.

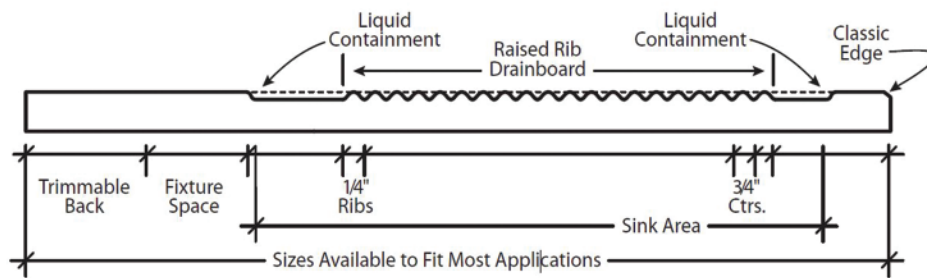
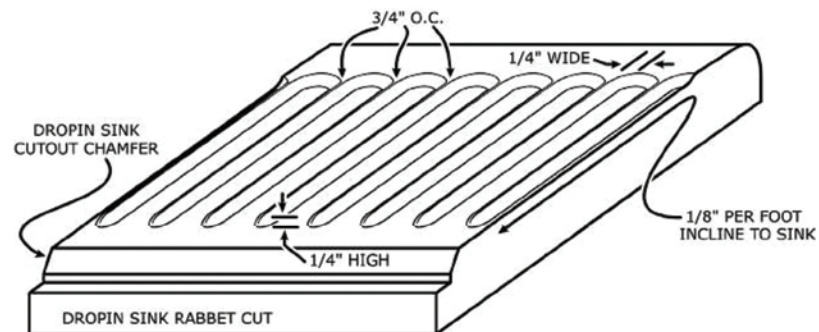

DURCON EPOXY DESIGN GUIDE

XXII. LIGHT REFLECTANCE VALUE (LRV)

- A. Light Reflectance Value (LRV) indicates the amount of visible light reflected by a surface material's color. When illuminated, different colors of different materials reflect or absorb unique quantities of light. These quantities are measured using a spectrophotometer, and the LRV is determined.
- B. The chart to the right shows the LRVs for popular worksurface colors of Durcon Epoxy.

EPOXY COLOR	LRV
Black Onyx	6
Graphite	13
Gray	32
Lunar White	56
Dark Khaki	15
Tan	41

XXIII. INSTALLATION

- A. Durcon recommends utilizing experienced epoxy installers for the installation of epoxy worksurfaces and sinks.
- B. Notify installer if tops are being installed prior to unistruts or uprights.
- C. Epoxy Material Guide available for installation and care and maintenance.
- D. SDS for Durcon Epoxy and Smooth-On® are available upon request.

XXIV. CERTIFICATIONS & MEMBERSHIPS

- A. Durcon Epoxy is certified Greenguard Gold.
- B. Durcon is certified by SCS Global Services for Indoor Air Quality.
- C. Durcon is certified NSF / ANSI 51.
- D. Durcon is certified ISO 9001:2015.
- E. Durcon is a member of the U.S. Green Building Council (USGBC).
- F. Durcon is a member of the American Institute of Architects (AIA).
- G. Durcon is a member of the Scientific Equipment Furniture Association (SEFA).
- H. Durcon is a member of International Surface Fabricators Association (ISFA).
- I. Durcon Epoxy is proudly made in the USA.



DURCON EPOXY DESIGN GUIDE

XXV. LABORATORY SPECIFICATIONS

Durcon Epoxy Resin Specification Sheet | Section 12 3653

PART 1 GENERAL

1.1 SUMMARY

A. Section Includes:

1. Epoxy resin [worksurfaces] [sinks] [and] [accessories].
2. Setting materials.

B. Related Sections:

1. Division 01: Administrative, procedural, and temporary work requirements.
2. Section [05 5000 - Metal Fabrications] [__ ____ - ____] - Steel supports.
3. Section [06 1000 - Rough Carpentry] [__ ____ - ____] - Wood supports.
4. Section [07 9200 - Joint Sealers] [__ ____ - ____] - Joint sealers.
5. Section [09 2900 - Gypsum Board] [__ ____ - ____] - Cementitious backer unit substrate.
6. Section [06 4100 - Architectural Wood Cabinets] [__ ____ - ____] - Base cabinets.
7. Section [12 3100 - Manufactured Wood Casework] [__ ____ - ____] - Base cabinets.
8. Section [12 3200 - Manufactured Metal Casework] [__ ____ - ____] - Base cabinets.
9. Section [12 3400 - Manufactured Plastic Casework] [__ ____ - ____] - Base cabinets.
10. Section [12 3500 - Specialty Casework] [__ ____ - ____] - Base cabinets.
11. Section [22 4000 - Plumbing Fixtures] [__ ____ - ____] - Plumbing fixtures and trim.

1.2 REFERENCES

A. ASTM International (ASTM):

1. D570 - Standard Test Method for Water Absorption of Plastics.
2. D635 - Standard Test Method for Rate of Burning and/or Extent and Time of Burning of Plastics in a Horizontal Position.
3. D648 - Standard Test Method for Deflection Temperature of Plastics Under Flexural Load in edgewise Position.
4. D695 - Standard Test Method for Compressive Properties of Rigid Plastics.
5. D696 - Standard Test Method for Coefficient of Linear Thermal Expansion of Plastics Between -30°C and 30°C With a Vitreous Silica Dilatometer.
6. D785 - Standard Test Method for Rockwell Hardness of Plastics and Electrical Insulating Materials.
7. D790 - Standard Test Method for Flexural Properties of Unreinforced and Reinforced Plastics and Electrical Insulating Materials.
8. D792 - Standard Test Method for Density and Specific Gravity (Relative Density) of Plastics by Displacement.
9. E84 - Standard Test Method for Surface Burning Characteristics of Building Materials.

DURCON EPOXY DESIGN GUIDE

- B. GREENGUARD Environmental Institute (GREENGUARD GOLD):
 - 1. Indoor Air Quality Certification Program.
 - 2. Children and Schools Certification Program.
- C. International Organization for Standardization (ISO) 9001 - 2015
Quality Management Systems - Requirements.
- D. NSF International / American National Standards Institute (NSF/ANSI) - 51 -
Food Equipment Materials.
- E. Scientific Certification Systems (SCS) - Recycled Content Certifications.
- F. Scientific Equipment and Furniture Association (SEFA) 3 - Work Surfaces.

1.3 SUBMITTALS

- A. Submittals for Review:
 - 1. Shop Drawings:
 - a. Submit plan, section, elevation and perspective drawings necessary to describe and convey layout, profiles, and product components, including edge conditions, joints, fitting and fixture locations, anchorage, accessories, and finish colors.
 - b. Verify actual measurements/openings by field measurements before fabrication; show recorded measurements on Shop Drawings.
 - c. Coordinate field measurements and fabrication schedule with construction progress to avoid construction delays.
 - 2. Product Data: Manufacturer's data sheets on each product to be used, including:
 - a. Preparation instructions and recommendations.
 - b. Storage and handling requirements and recommendations.
 - c. Installation methods.
 - 3. Samples:
 - a. Selection samples: For each finish product specified, submit complete set of color chips representing manufacturer's full range of standard colors.
 - b. Verification samples: For each finish product specified, submit samples representing actual product color; supplied product color and gloss may vary slightly from supplied samples.
- B. Quality Control Submittals:
 - 1. Test Reports: Certified test reports or recognized evaluation reports showing compliance with specified performance characteristics and physical properties.
- C. Sustainable Design Submittals [APPLICABLE FOR GREENSTONE EPOXY ONLY]:
 - 1. Recycled Content: Certify percentages of post-consumer and pre-consumer recycled content.
 - 2. Regional Materials: Certify products extracted, processed, and manufactured within 500 mile radius of Project site.

DURCON EPOXY DESIGN GUIDE

3. Low-emitting Materials: Certify volatile organic compound (VOC) content.

D. Closeout Submittals:

1. Maintenance Data:

- a. Provide maintenance, cleaning, and life cycle information.
- b. Include recommended cleaning materials and procedures, and list of materials detrimental to epoxy resin.

1.4 QUALITY ASSURANCE

A. Manufacturer Qualifications:

1. Primary products furnished by single manufacturer with minimum [10] years [documented] experience in work of this Section.
2. Products manufactured in ISO 9001 certified facility.

B. Installer Qualifications: Minimum [5] years [documented] experience in work of this Section.

C. Mockup:

1. Construct worksurface mockup, [6] feet wide x full depth.
2. Include worksurface, and trim.
3. Locate [where directed.]
4. Approved mockup may [not] remain as part of the Work.

1.5 DELIVERY, STORAGE, AND HANDLING

A. Delivery:

1. Use pallets larger than sheets during transportation.
2. Package materials to prevent damage during shipping and handling.

B. Storage:

1. Store products in enclosed area protected from ultraviolet.
2. Store products in manufacturer's unopened packaging until ready for installation.
3. Store panels using protective dividers to avoid damage to surfaces.
4. For horizontal storage, store sheets on pallets of equal or greater size than sheets with protective layer between pallet and sheet and on top of uppermost sheet.
5. Do not store sheets or fabricated panels vertically.

C. Handling:

1. If protective film is provided, do not remove until panel has been installed.
2. Handle sheets to prevent damage.
3. Remove stickers immediately after installation.

DURCON EPOXY DESIGN GUIDE

PART 2 PRODUCTS

2.1 MANUFACTURERS

- A. Contract Documents are based on products by: Durcon A Wilsonart Company, 206 Allison Dr., Taylor, TX 76574, 512-595-8000, www.durcon.com.
- B. Substitutions: [Under provisions of Division 01.] [Not permitted.]

2.2 MATERIALS

A. Solid Epoxy Resin:

1. Sheets cast from modified epoxy resin and non-asbestos inert fillers; compounded mixture cured and thermoset specifically from formulation to provide exceptional physical and chemical resistance required in medium to heavy duty laboratory environments.

**** OR ****

2. Sheets cast from modified epoxy resin and non-asbestos inert fillers with 10 percent of filler certified as post-consumer glass by SCS; compounded mixture cured and thermoset specifically from formulation to provide exceptional physical and chemical resistance required in medium to heavy duty laboratory environments.
3. Sheets monolithic throughout without surface coating application.
4. Certified to NSF/ANSI 51.
5. Certified by GREENGUARD under Indoor Air Quality and Greenguard Gold Certification programs.
6. Physical properties; minimum acceptable physical performance in accordance with SEFA 3 testing procedures:
 - a. Density/specific gravity: Tested to ASTM D792; minimum test rating of 133.6 lb/ft³ or 2.14 g/cm³.
 - b. Rockwell hardness: Tested to ASTM D785; minimum M scale rating of 109.
 - c. Fire resistance: tested to ASTM D635; classified as self-extinguishing.
 - d. Surface burning characteristics: Tested to ASTM E84; flame spread index 5 and smoke developed index of 185.
 - e. Coefficient of linear thermal expansion: Tested to ASTM D696; rating of 1.2 x 10⁻⁵ in/in°F or 2.15 x 10⁻⁵ mm/mm°C.
 - f. Heat deflection: Tested to ASTM D648; maximum 293°F or 145°C .
 - g. Flexural strength: Tested to ASTM D790; minimum rating 12.6 KPSI or 87 Mpa.
 - h. Flexural modulus: Tested to ASTM D790; 3240 KPSI or 22.4 Gpa.
 - i. Water absorption, 24 hours: tested to ASTM D570; maximum 0.03% by weight.
 - j. Compression strength: Tested to ASTM D695; minimum 32.7 kpsi or 226 Mpa.
 - k. Chemical resistance; minimum acceptable chemical resistance performance in accordance with SEFA 3:

DURCON EPOXY DESIGN GUIDE

CHEMICAL Tested	TEST method	RATING
Acetate, Amyl	A	1
Acetate, Ethyl	A	1
Acetic Acid 98%	B	0
Acetone	A	1
Acid Dichromate 5%	B	0
Alcohol, Butyl	A	1
Alcohol, Ethyl	A	1
Alcohol, Methyl	A	0
Ammonium Hydroxide 28%	B	1
Benzene	A	1
Carbon Tetrachloride	A	1
Chloroform	A	1
Chromic Acid 60%	B	3
Cresol	A	1
Dichloroacetic Acid	A	1
Dimethylformamide	A	1
Dioxane	A	1
Ethyl Ether	A	0
Formaldehyde 37%	A	0
Formic Acid 90%	B	1
Furfural	A	1
Gasoline	A	0
Hydrochloric Acid 37%	B	1
Hydrofluoric Acid 48%	B	2
Hydrogen Peroxide 28%	B	0
Iodine, Tincture of	B	0
Methyl Ethyl Ketone	A	0
Methylene Chloride	A	1
Monochlorobenzene	A	1
Naphthalene	A	0
Nitric Acid 20%	B	0
Nitric Acid 30%	B	1
Nitric Acid 70%	B	1
Phenol 90%	A	1
Phosphoric Acid 85%	B	0
Silver Nitrate, Saturated	B	1
Sodium Hydroxide 10%	B	1
Sodium Hydroxide 20%	B	1
Sodium Hydroxide 40%	B	1
Sodium Hydroxide, Flake	B	0
Sodium Sulfide, Saturated	B	1
Sulfuric Acid 25%	B	0
Sulfuric Acid 85%	B	1
Sulfuric Acid 96%	B	3
Sulfuric Acid 85% & Nitric Acid 70%, Equal Parts	B	1
Toluene	A	1
Trichloroethylene	A	1
Xylene	A	1
Zinc Chloride, Saturated	B	0

Testing Method Descriptions:

Method A - Volatile chemicals (organic solvents): Cotton ball saturated with test reagent is placed in one-ounce bottle (20 x 75mm test tube or similar container) with reservoir of liquid above ball. Container is inverted on test material for period of 24 hours at standard temperature 23°C +/- 2°C (73°F +/- 4°F).

Method B - Non Volatile Chemicals: Five drops (1/4 cc) of test reagent are placed on test material surface. Reagent is then covered with watch glass (25 mm) for period of no less than 24 hours at standard temperature 23°C +/- 2°C (73°F +/- 4°F).

Result Definitions:

0 - No Effect: No detectible change in material surface.

1 - Good: Slight detectable change in color or gloss but no change to function or life of work surface material.

2 - Fair: Slight surface etching or severe staining. Clearly discernable change in color or gloss but no significant impairment of surface life or function.

3 - Poor: Pitting, cratering or erosion of work surface material; obvious and significant deterioration. Objectionable change in appearance due to surface discoloration.

DURCON EPOXY DESIGN GUIDE

7. Color: Contact Durcon rep for color availability and pricing.] [Black Onyx.] [Graphite.] [Gray.] [Lunar White.] [_____ .]

2.3 ACCESSORIES

- A. Provide solid epoxy resin [laboratory shelving] [laboratory fume hood base work surfaces] [pegboards] [reagent racks] where indicated.
- B. Installation Materials: Manufacturer's joint adhesive, panel adhesive, and sealants as required to suit project conditions.

2.4 FABRICATION

- A. Fabricated tops and accessories in accordance with manufacturer's recommendations, approved Shop Drawings, and SEFA 3.
- B. Epoxy Resin Worksurfaces:
 1. Thickness:
 - a. [3/4 inch (19 mm)] [1 inch (25 mm)] [1-1/4 inches (32 mm)] unless otherwise indicated.
 - b. Check each sheet at factory for required thickness.
 - c. Maximum variation in thickness: plus or minus 1/16 inch (1.6 mm) from corner to corner.
 2. Warpage:
 - a. Inspect tops for warpage prior to fabrication by placing on true flat surface.
 - b. Maximum allowable warpage: 1/16 inch (1.5 mm) in 36 inch (900 mm) span or 3/16 inch (4.5 mm) in 96 inch (2400 mm) span.
 3. Fabrication:
 - a. Shop fabricate in longest practical lengths.
 - b. Bond joints with highly chemical resistant cement with properties and color similar to base material.
 - c. Provide 1/8 inch (3 mm) drip groove at underside of exposed edges, set back 1/2 inch (13 mm) from face.
 - d. Finish exposed edges.
 4. Fabricate tops [flat] [with 1/4 inch (6 mm) raised marine edge.] [Flat with 1/4 inch (6 mm) raised marine edge at epoxy sink locations.
 5. Edge treatment: [Standard 1/8 inch (2 mm) chamfered edge.] [Standard 1/4 inch (2 mm) radius edge.] [Standard 1/8 inch (2 mm) chamfered edge with drip groove.] [Standard 1/4 inch (2 mm) radius edge with drip groove.] [As indicated on Drawings.]
 6. Corner treatment: exposed corners shall be eased slightly for safety.

DURCON EPOXY DESIGN GUIDE

7. Back and end splashes:
 - a. Supplied loose for field installation.
 - b. Same material and thickness as worksurfaces.
 - c. [4] [__] inches ([100] [__] mm) high unless otherwise indicated.
 - d. Top-mounted end splash where worksurfaces abut adjacent construction at and locations indicated on Drawings.
 8. Joints: [As indicated on Drawings.] [Maximum 1/8 inch (2 mm), bonded with epoxy grout.] [____.]
 9. Make joints between two benches level.
 10. Locate joints away from sinks and over or near supports.
 11. Sink cutouts: [As indicated on Drawings.] [Routed for drop-in sink.] [Routed for undermount sink.] [Sink cutout with cover:] [____.]
 12. Allowable tolerances:
 - a. Square: Plus or minus 1/64 inch (0.4 mm) for each 12 inches (300 mm) of length.
 - b. Location of cutouts and drilled openings: Plus or minus 1/8 inch (3 mm) of design dimension.
 - c. Size of cutouts and drilled openings: Plus 1/8 inch (3 mm) or minus 0 inches (0 mm).
- C. Epoxy Resin Sinks:
1. Mold sinks from thermosetting epoxy resin.
 2. Mold interior corners to radius. Slope sink base to drain outlet.
 3. Provide 1-1/2 inch (38 mm) outlet with open ended standpipe; standpipe overflow 2 inches (50 mm) shorter than depth of sink.
 4. Unless otherwise indicated, fabricate sinks of drop-in design supported by upper flange from worksurface.
 5. Color: To match adjacent worksurface.

PART 3 EXECUTION

3.1 EXAMINATION

- A. Do not begin installation until cabinets have been installed.
- B. Confirm that surfaces to receive tops are plumb and level, with maximum deflection of 1/4 inch (6 mm) in 20 feet (6 m).

3.2 PREPARATION

- A. Clean surfaces just prior to installation.
- B. Prepare surfaces using methods recommended by manufacturer.

DURCON EPOXY DESIGN GUIDE

3.3 INSTALLATION

- A. Install in accordance with manufacturer's instructions and approved Shop Drawings.
- B. Install tops plumb and level.
- C. Scribe to adjacent surfaces in accordance with manufacturer's recommendations.
- D. Fasten tops to supporting construction with adhesives appropriate for use with adjoining construction and as recommended by manufacturer.
- E. Form field joints using manufacturer's recommended adhesive. Form joints to be inconspicuous and nonporous.
- F. Install [laboratory shelving] [laboratory fume hood base work surfaces] [pegboards] [reagent racks] using fasteners and adhesive appropriate for use with adjoining construction and as recommended by manufacturer.

3.4 PROTECTION

- A. Protect installed products until completion of Project.
- B. Touch up, repair, or replace damaged products.

----- END OF SECTION -----

XXVI. REFERENCE INFORMATION

Scientific Furniture Tests & Their Relevance to Laboratory Applications

by Durcon Technical Services

Chemical Resistance

These tests are reflective of the worksurface's resistance to the major chemical substance classifications (acids, bases and solvents). Because it is impossible to be 100% sure of the top's performance against any unlisted substance, we recommend the customer check using a sample and the actual material in question. It should be noted that some materials stain the top rather than chemically harming it. This group includes silver nitrate and zinc chloride.

Rockwell Hardness "M" Scale

This test measures the force needed to penetrate the surface of the sample. It is generally related to scratch and mar resistance. There are various Rockwell scales and the correct letter designation for the specification is critical.

Water Absorption ASTM D-570

This test measures the amount of water absorbed during immersion in water. It is most relevant to applications where high humidity or long term submersion in water may be present as service conditions for the product. The state of the material after it is removed from the water (if any separation of layers or swelling is present) should also be taken into consideration when evaluating the test results.

Fire Resistance ASTM D-635

This test measures the material's response to being subjected to an open flame. The sample is marked with start and finish lines. The flame is applied for a set period of time and then removed. The sample is judged on the time it takes for the flame to travel between the lines, or whether it ever gets to the starting line after the flame is removed (i.e. self-extinguishing).

Heat Deflection ASTM D-648

This test reflects the temperature at which the material bends under heat and pressure. It is most relevant to high heat applications or very long term medium heat conditions like an oven or high temperature bath that is constantly operating.

DURCON EPOXY DESIGN GUIDE

Flex Strength and Flex Modulus ASTM D-790

The flex modulus refers to the rate at which a material deflects (bends or sags) as weight is put on it. The flex strength refers only to the breaking point. If the material bends significantly before it breaks (as epoxy tops do), the bending (modulus) data is more relevant than the breaking data, because earlier bending would be detected as distortion of the top before the top ever broke. This is particularly true in shelf or cantilever type applications. For these reasons, in most design work, the flex modulus should be considered more important than the flex strength.

Specific Gravity ASTM D-792

This can be compared to get an idea of the relative weights of various products. The specific gravity is the ratio of the weight of the material as compared to the weight of the same volume of water. The density is the material's actual weight per unit of volume.

Compressive Strength ASTM D-695

The compressive strength test refers to the strength of the material as it is squeezed across its thickness (compressed). The compressive strength of epoxy material is generally far greater than that of the casework below it. It is so much greater that it is practically impossible to apply enough weight to the casework/top assembly to get the countertop to fail in a compression mode before the load is too heavy for the casework to bear.

Tensile Strength ASTM D-638

Tensile strength is the strength of the material as it is pulled from end to end like stretching a rubber band. As with the compressive strength, this test reflects the material behavior under conditions not reproducible under normal conditions.

Flame Spread & Smoke Development Index ASTM E84

The purpose of this test is to provide the comparative measurements of surface flame and smoke development of materials with that of select grade red oak and fiber-reinforced cement board, Grade II, under specific fire exposure conditions. During the 10-minute test duration, flamespread over the specimen surface and density of the resulting smoke are measured and recorded.

Resistance to Dry Heat EN 438-2:16

An aluminum block is heated to 160°C, then placed on top of the worksurface for 20 minutes, then removed. After 24 hours the impact to the surface is examined and rated.

Resistance to Wet Heat EN12791

An aluminum block is heated to 100°C, then set on a wet cloth on top of the worksurface for 20 minutes, then removed. After 24 hours the impact to the surface is examined and rated.

XXVII. EPOXY RESIN CHEMISTRY

The curing of an epoxy resin system normally takes place in stages. The first of these is the combining of the two reactive materials - the epoxy resin and the curing agent. Normally, these two components are kept apart until reaction is desired. The resin is normally a viscous liquid and the curing agent may be a liquid or a low-melting solid.

When combined, and a catalyst and heat are added, the resin and curing agent react with a release of additional heat. Reactive epoxy systems always release heat when curing, thus, they are classified as exothermic reactions. The exothermic heat acts to speed reaction. This second stage of reaction results in formation of linear chains of combined epoxy resin and curing agent. As the linear chains form, the material is still in a liquid form but viscosity is increasing rapidly.

Heat and catalyst promote further reaction. The linear polymer chains are combined through chemical reactions in a cross-linking process to form a polymerized system approaching an extremely high molecular weight. During this third stage of reaction, the material changes from a viscous liquid to a solid gel and is developing strength. It is at this stage that, at Durcon, the material is removed from the mold and placed in a cure oven. This material, just strong enough to be moved, is at a stage of incomplete cure, relatively weak and unsuitable for the intended use.

The final stage of curing, a lengthy process carried out at an elevated temperature at Durcon, results in completion of the cross-linking process. The final product is a very strong, chemically resistant material which is suitable for a variety of applications.

DEVELOPMENT OF CURE: THERMOSETTING (EPOXY) SYSTEM

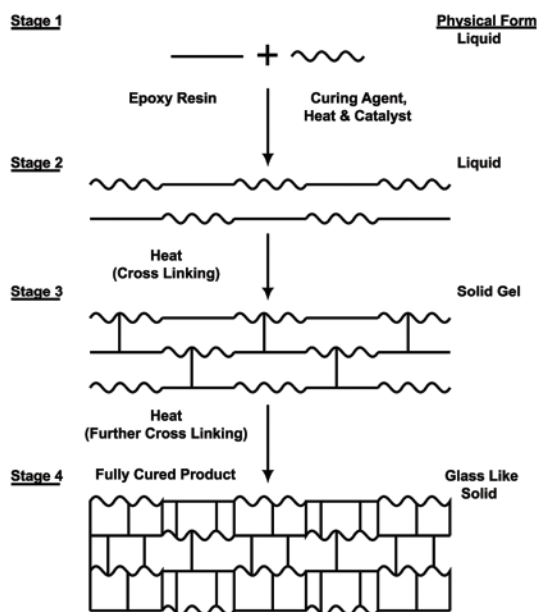

XXVIII. GLOSSARY

TERM DEFINITION

ADA Compliant DropIn Sinks ADA compliant DropIn sinks are top mounted sinks molded to a 5" inside dimension depth. This shallow depth and the elimination of sink supports helps meet the clearance requirements for Americans with Disabilities Act standards.

Adhesive Two-part chemical resistant epoxy adhesive is available upon request for installation of tops and sinks. We will be happy to determine proper amount needed for your project. Available in quart sizes.

Applied End Splash / Curb Field application of a loose curb at the end of corner assemblies.

Backsplash *See Loose Curb*

Balance Table Stable, chemical resistant worksurface ideal for precision metering and measuring. The balance table is shipped unassembled with complete assembly instructions provided.

Butt Joint The point where two tops will meet on the cabinets. The longest piece we manufacture is 96". Indicate your joint requirements on the drawings you submit to us. If you do not indicate the joint requirements on your drawings, Durcon will determine their placement utilizing maximum piece sizes to reduce the number of joints.

C & F Cost and Freight to named overseas port of import. Under this term the quote includes a price for the goods and the cost of transportation to the named point of debarkation.

CIF Cost, Insurance and Freight to named overseas port of import. Under this term, the quote includes a price for the goods, including insurance, all transportation, and miscellaneous charges to the point of debarkation from vessel or aircraft.

DURCON EPOXY DESIGN GUIDE

TERM DEFINITION

Classic MarineTop 1/4" high raised edge, 1" wide. Available in outside thicknesses of 1" or 1-1/4". Standard marine edge sizes can be found in the literature. When requesting a quotation or ordering marine edge tops, advise which sides will have marine edge.

ClassicTop Standard flat epoxy resin top with 1/8" machined bevel or 1/4" machined radius finished edges. When ordering, Durcon must be advised of which edges should have a finished edge, if any. Available in thicknesses of 3/4", 1" or 1-1/4".

Colors Please contact a Durcon representative for current color availability and pricing when requesting a quotation or placing an order.

Cupsinks Smaller molded sinks used primarily for quick disposal in areas of limited space such as fume hoods and narrow counter tops. Available in round and oval styles. Cupsinks are frequently used in fume hoods. Sizes and styles are shown in our literature. Threads on Cupsinks are 1-1/2" N.P.S.M.

Cutouts Based upon your drawings, cutouts are made for sinks, cupsinks, fixtures, service holes, etc. Your drawing must show exact location and dimensions of cutout.

Delivery Dates given in quotations indicate the date of shipment from our dock in Taylor, Texas, USA. Actual delivery dates will depend on the method of shipments and the destination. Working with our freight forwarder, we can give you approximate transit time for your particular requirement.

Dished Fume Hood Molded tops with wide side rails to allow for fume hood mounting. Front and back rails are wider than marine edge for spill retention and fume hood mounting. Dished fume hood worksurfaces are available in outside thicknesses of 1-1/4" and 1". A complete list of molded sizes with 3/8" deep dish can be found in our literature and on our website.

DURCON EPOXY DESIGN GUIDE

TERM DEFINITION

Disposal Cutout Enlarging of outlet opening in our standard sinks to accommodate the collar of a garbage disposal. Specify size required.

Double DropIn Sink All options for double DropIn sinks as well as further details can be found in the Durcon Epoxy Product Catalog, Page 10.

Double Undermount Sink Two standard undermount sinks glued together. Durcon must have a drawing showing which sides to place together with outlet location indicated. Sinks can be provided separately if sink cutouts are made as two openings instead of one opening. This lowers the cost by eliminating gluing and allows one sink to be replaced if required.

DropIn Sink Sinks molded with a rim for top mounting. This design eliminates sink supports under the sink.

DropIn Trough DropIn troughs are flush mounted eliminating the exposed area under the worksurface lip. DropIn Troughs eliminate need for trough supports, while providing excellent joint integrity.

Efficiency Top Designed to add flexibility to any school laboratory, this island unit can be used as a student laboratory tabletop to accommodate multiple students or as an instructor's table (for example Durcon Trifacia or Octagonal workstations). It can be joined to wall benches using a factory-supplied connecting piece. A center positioned sink cutout of any size can be cut for use.

Ex-Works Factory Buyer assumes responsibility when goods leave our plant. Price quoted does not include transportation charges.

Finished Edge Edges that will be exposed are beveled or radiused and finished upon request for all fabricated pieces. Edges at butt joints will not be finished. Edges to be finished should be marked with Bev, Rad or on drawings (see Section IV).

DURCON EPOXY DESIGN GUIDE

TERM DEFINITION

Flat DrainTop Flat DrainTops feature a unique raised rim on all four sides for control of spilled liquids and radiused edges and corners on the outside for user comfort and safety. The drain board sections are designed with round edges and a gentle slope toward the sink from all directions to facilitate easy and thorough draining.

Irrevocable Letter of Credit A document issued and guaranteed by a bank per instructions by a buyer of goods, authorizing the seller to draw a specified sum of money under specified terms, usually the receipt by the bank of certain documents within a given time.

Loose Curb Backsplash manufactured and shipped as a separate piece and installed at the job site. Loose curbs are recommended to reduce cost of installation, particularly where wall alignment may not be perfect. Typical loose curb height measures 4" from the surface after installation.

Marine Insurance Insurance that compensates the owners of goods transported overseas in the event of loss that cannot be legally recovered from the carrier.

Open Account A trade arrangement in which goods are shipped to a buyer and are to be paid for within a certain agreed upon time period. Standard domestic terms are Net 30 days.

Outlet Available in epoxy or polypropylene. 1-1/2" N.P.S.M. sink drain with integral tailpiece. Outlets fit into outlet holes in all of our molded sinks. A locknut is supplied with each outlet to secure outlet to the sink while the silicone or adhesive dries properly. The locknut should be hand tightened only.

DURCON EPOXY DESIGN GUIDE

TERM DEFINITION

Overflow Fits into the sink outlet to allow for constant fluid level in a sink. Available in heights of 4", 6", 8" and 10". Please specify which style you will require. Recommend that the height of the overflow be at least 2" below the overall height of the sink.

Peg Supplied with pegboards to support drying glassware. Black or white pegs are available in lengths of 6-1/2", and 8". Peg length and color are based upon your request. If not specified, Black will be provided.

Pegboard Vertical pegboards supplied with polypropylene pegs set at a 30° angle to the base for effective support and draining of laboratory glassware. Complete listing of available sizes can be found in our literature. Stainless steel drip trays used to catch drips and hold beakers below the pegboard are available through Durcon.

Pegboard Drip Tray Stainless steel Drip Trays are used to catch drips and hold beakers below the pegboard. Standard tray width is 2". PVC tubing to direct liquids into a sink basin is included. Stainless steel screens not included.

Rabbit Cut A groove, channel or recess is cut into, but not through, the top surface to accommodate lipped or flanged fixtures, etc.

Sight Draft A draft that is payable upon presentation to the drawee.

Sink Molded epoxy resin sinks are available in standard sizes with standard outlet hole locations as indicated in our literature. All molded sinks have interior corners coved to a 1-5/8" radius and bottoms are pitched to the outlet opening. The bottom and walls are a minimum of 1/2" thick.

Sink Support A leveling bracket used to support the sink under the cabinet. Supports are supplied by the cabinet manufacturer.

DURCON EPOXY DESIGN GUIDE

TERM DEFINITION

Slab Standard molded counter tops with no finishing or machining. Available in the sizes shown in our literature. Styles available include dished fume hood tops, marine edge and flat.

Square Cut Square cut edge, sanded and colored, but has no bevel.

Tailpiece Tailpieces for connecting sink outlets to plumbing are supplied as an integrally molded section of our outlets (please refer to outlet section for more information).

Thickness Depth of outside edge of top. Options are 3/4", 1" and 1-1/4".

Trough Installation Kit Supplied with all undermount troughs (also available upon request to assist in finishing unfinished edges). Kit includes two-part epoxy, fiber cloth, two clips, 220 grit wet/dry sandpaper, finishing pad, finish oil and instructions.

Undermount Sinks Epoxy resin sink that is mounted below the worksurface and is accessed via a standard cutout in the worksurface. Undermount units require an under sink support system (**not supplied by Durcon**).

DURCON EPOXY DESIGN GUIDE

XXIX. CONTACT INFORMATION

Durcon A Wilsonart Company®
206 Allison Drive
Taylor, Texas 76574

Phone: 512-595-8000
Fax: 512-595-8400
Web: <https://www.durcon.com>
Email: sales@durcon.com

DURCON®
A WILSONART COMPANY



Other References:

SEFA website for recommended practices regarding worksurfaces and installation.

<http://www.sefalabs.com>

U.S. Department of Justice's Americans with Disabilities Act (ADA) Home Page

<https://www.ada.gov/adahom1.htm>

XXX. NOTES



DURCON A WILSONART COMPANY
206 ALLISON DRIVE
TAYLOR, TEXAS 76574

WWW.DURCON.COM
512-595-8000